



Government of Nepal  
National Reconstruction Authority  
Singhadurbar, Kathmandu

Final inspection

# CORRECTION/ EXCEPTION MANUAL

2<sup>nd</sup> inspection

for  
MASONRY STRUCTURE

1<sup>st</sup> inspection

for

houses that have been built under the  
HOUSING RECONSTRUCTION PROGRAMME

Copyright: National Reconstruction Authority  
Version 1: May 2017  
Printed copy: 5000pcs

# **CORRECTION/EXCEPTION MANUAL for MASONRY STRUCTURE**

for houses that have been built under the  
HOUSING RECONSTRUCTION PROGRAMME



**Government of Nepal  
National Reconstruction Authority  
Singhadurbar, Kathmandu**

This Page is Intentionally Left Blank



## FOREWORD



I would like to congratulate all involved in the development of the Corrections / Exceptions Manual for Reconstruction of Earthquake Resistant Houses, which has been produced by the National Reconstruction Authority (NRA) to support households who have already rebuilt, or have started rebuilding, under reconstruction programme to implement any corrections required to comply with the standards as set out in the inspection guidelines. The manual also addresses exceptions outside of the MRs which are structurally sound.

Thirty-one districts have been identified by the GoN Post Disaster Needs Assessment (PDNA) as being earthquake affected. To date, almost 750,000 households across the 31 districts have been identified as being eligible to receive 300,000 NPRs housing reconstruction grant. The grant is disbursed in number of tranches based on compliant construction. Unfortunately, the compliance rate is currently estimated to be very low which means that many households are not approved to receive the next tranche of the grant. Every effort is required to support households to meet the compliance standards so that they can receive the full grant amount. This manual has been developed for technical staff to identify exceptions in relation to certain MRs under certain conditions and also to go through the process of implementing required corrections so that they could guide the households.

I look forward to seeing the manual implemented across the earthquake affected districts and to seeing the impact that it will have. This represents another positive step forward in the reconstruction process, and will support households to overcome non-compliance issues and secure approval to receive tranches of the reconstruction grant and to have safe, compliant houses.

Dr. Govind Raj Pokharel  
Chief Executive Officer, NRA

This Page is Intentionally Left Blank

## **PREFACE**



Under the housing reconstruction programme, houses that have been constructed or are in the process of construction need to comply with the Minimum Requirements (MRs) for compliant construction. In order to receive the housing reconstruction grant, the buildings need to comply with all the descriptions mentioned in the inspection check sheet which were formulated on the basis of MRs. The houses that have been reconstructed till date do not fulfill all the MRs as a result many houses have not been approved to receive the grant. Hence, this manual is prepared to introduce the exceptional cases, other than mentioned in MRs. and several correction measures along with their step by step procedures for mitigation measures.

Beneficiaries whose houses were considered as non-compliant will get a chance to make their house compliant if their house falls under any case of the exception or adopt the appropriate correction measures mentioned in this manual. On the other hand, this manual is helpful to all the engineers who are working for the reconstruction and are deployed by GoN for inspection. As many exceptional cases and tolerance were introduced in this manual, it will help them to fill up the inspection check sheet.

The manual has been divided into two sections so that they could be conveniently used for inspection and provide correction order, if need.

PART-A: Exception / Correction

PART-B: Mitigation measures

Dr. Hari Ram Parajuli  
Executive member, NRA

# Standardization Committee, NRA

## for Reconstruction of Earthquake Resistant Houses

### Member

Dr. Hari Ram Parajuli	Chairman (Executive member, NRA)
Er. Tapendra Bahadur Khadka	Member (MoUD-CLPIU)
Er. Ishwor Chandra Marahatta	Member (Project Director, MoFALD-CLPIU)
Er. Dwarika Shrestha	Member (Joint-secretary, NRA)

### Invited Experts

Prof. Dr. Prem Nath Maskey	IOE, TU
Prof. Dr. Hikmat Raj Joshi	IOE, TU
Prof. Dr. Gokarna Bahadur Motra	IOE, TU
Dr. Jagat Kumar Shrestha	IOE, TU
Dr. Hiroshi Imai	Consultant, JICA
Dr. Ramesh Guragain	Deputy Ex. Director, NSET
Dr. Narayan Marasini	National Technical Co-ordinator, HRRP
Er. Kuber Bogati	HRRP
Er. Mahohar Raj Bhandari	Adviser, NRA, Private consulting
Er. Prakash Thapa	Joint-secretary, NRA
Er. Sagar Krishna Joshi	Senior Division Engineer, NRA
Er. Purna P. Kalaria	Adviser, NRA, Ex-secretary GoN
Er. Parikshit Kalaria	Senior Division Engineer, MoUD-CLPIU
Er. Rajkaji Shrestha	Senior Division Engineer, NRA
Er. Manoj Nakarmi	Building code section, DUDBC

## **ACKNOWLEDGEMENTS**

We would like to express deepest gratitude to JICA, USAID/NSET, HRRP, IOE,TU for their initiation and continuous involvement during the preparation of this manual.

Our sincere thanks to the respected senior experts, Prof. Dr. Prem Nath Maskey, Prof. Dr. Hikmat Raj Joshi, Prof. Dr. Gokarna Bahadur Motra, Mr. Purna P. Kadaria, and Er. Manohar Raj Bhandari for their support and suggestions during the many discussion on critical issues which were required to finalize this manual.

We also thanks to Dr. Hiroshi Imai, Dr. Ramesh Guragain, Dr. Jagat Kumar Shrestha, Ar. Sabika Mastran, Ar. Ambu Chaudhary, Er. Kuber Bogati, Siobhan Kennedy, and Er. Sujan Tripathi.

We would like to congratulate all personnel involved, both directly and indirectly, for their valuable contribution to the preparation of this manual.

Standardization Committee, NRA  
for Reconstruction of Earthquake Resistant Houses

## ACRONYMS

GoN	Government of Nepal
PDNA	Post Disaster Needs Assessment
NRA	National Reconstruction Authority
MoUD	Ministry of Urban Development
DUDBC	Department of Urban Development and Building Construction
MoFALD	Ministry of Federal Affairs and Local Development
CL-PIU	Central Level Project Implementation Unit
DL-PIU	District Level Project Implementation Unit
IOE, TU	Institute of Engineering, Tribhuvan University
JICA	Japan International Cooperation Agency
NSET	National Society for Earthquake Technology-Nepal
USAID	United States Agency for International Development
HRRP	Housing Recovery and Reconstruction Platform-Nepal
MRs	Minimum Requirements
NBC	Nepal National Building Code
IS	Indian Standard
SMM	Stone Masonry in Mud mortar
BMM	Brick Masonry in Mud mortar
SMC	Stone Masonry in Cement mortar
BMC	Brick Masonry in Cement mortar
RCC	Reinforced Cement Concrete
RC	Reinforced Concrete
CGI	Corrugated Galvanized Iron
GI	Galvanized Iron
PP	Polypropylene

This Page is Intentionally Left Blank

# Contents

FOREWORD-----	
PREFACE-----	
ACKNOWLEDGEMENTS-----	
ACRONYMS-----	
BACK GROUND-----	i
SCOPE -----	ii

## PART-A: Exception / Correction

1.	Site Selection -----	2
	1.1 Site condition (treatment / retaining wall)	
2.	Shape and Size of Building -----	4
	2.1 Span of wall, size of room, height of wall	
	2.2 Shape of building(proportion)	
	2.3 Number of storeys	
3.	Materials -----	10
	3.1 Using improper materials, mix use of materials	
4.	Foundation -----	12
	4.1 Insufficient foundation	
5.	Vertical Member -----	14
	5.1 RC vertical member	
	5.2 Wooden vertical member	
6.	Plinth Beam -----	18
	6.1 No plinth beam / level of plinth	
7.	Wall -----	20
	7.1 Weak masonry/ lack of through stone	
	7.2 Vulnerable gable wall	
8.	Door and Windows -----	24
	8.1 Inappropriate position and size of openings	
9.	Horizontal Band -----	26
	9.1 RC horizontal band	
	9.2 Wooden horizontal band	
10.	Roof -----	30
	10.1 Connection / heavy material for roofing	



## PART-B: Mitigation Measures

1. Retaining wall -----	34
2. Buttress -----	35
3. Cross wall -----	36
4. Vertical member (RC) -----	37
5. Vertical member (GI wire)-----	42
6. Vertical member (Wood) -----	47
7. Strengthen opening-----	48
8. Horizontal member (RC) -----	52
9. Horizontal member (GI wire) -----	56
10. Horizontal member (Wood) -----	60
11. Strengthen wall by jacketing -----	62

## ANNEX

### ANNEX-1

1. Wooden frame with wooden connection-----	74
2. Wooden frame with diagonal bracing with wooden connection--	75
3. Wooden frame with Iron rod connection -----	76
4. Wooden frame with diagonal bracing with iron rod connection --	77
5. Gabion wire mesh wrappings -----	78
6. Precast concrete frame with iron rod connection -----	79

### ANNEX-2

1. Wooden/Bamboo sections-----	82
2. Wooden/Bamboo sections (outer side)-----	83
3. Wooden/Bamboo sections(both sides)-----	84
4. Wooden/Bamboo sections (both sides) -----	85
5. Iron sections-----	86
6. Iron sections with prefab panels-----	87

## BACKGROUND

Under the Government of Nepal (GoN) housing reconstruction programme, a housing reconstruction grant is disbursed based on construction compliance with the Minimum Requirements (MRs) as per the Nepal National Building Code (NBC) and the inspection checklists. Many houses have been found during inspection to be non-compliant with these MRs. These buildings are therefore vulnerable to future earthquakes, as they do not have the required earthquake resistant elements. In order to bring these houses to compliance, corrective measures are required.

This manual has been developed to support engineers responsible for the compliance inspection process. The engineers will use this manual to provide advice and guidance to households for the implementation of required corrective measures. Home owners will need to complete these corrective measures in order to be eligible to receive the subsequent tranches of the housing reconstruction grant.



## SCOPE

### □ Applicability

This manual is applicable within certain limitations as guided by NBC 202 and NBC 203, which are based on NBC 105 seismic design code.

The corrections and the exceptions set forth in this manual are applicable only for the residential houses that have been constructed after Gorkha earthquake 2015 under the GoN housing reconstruction program. The manual intends to achieve the minimum acceptable structural safety envisioned in NBC 105.

The designs mentioned in the manual are ready-to-use designs for all structural components, but some provisions mentioned are set as advisory measures.

### □ Limitations

***This corrections / exceptions manual covers only load bearing masonry buildings under the GoN housing reconstruction programme. The corrective measures are only for buildings that are newly constructed, or under construction.***

This manual has certain limitations and is only relevant for buildings which are:

I. Residential and fall under category 'C' and 'D' of NBC.

- ✓ Category "A": Modern building to be built, based on the international state-of-the-art, also in pursuance of the building codes to be followed in developed countries.
- ✓ Category "B": Buildings with plinth area of more than One Thousand square feet, with more than three floors including the ground floor or with structural span of more than 4.5 meters.
- ✓ Category "C": Buildings with plinth area of up to One Thousand square feet, with up to three floors including the ground floor or with structural span of up to 4.5 meters.
- ✓ Category "D": Small houses, sheds made of baked or unbaked brick, stone, clay, bamboo, grass etc., except those set forth in clauses (a), (b) and (c).

*\* If the construction up to plinth level is as per requirement, applications can be recommended for second tranches. Correction or mitigation works at super structure should be made before third tranche.*

This Page is Intentionally Left Blank

## PART-A: Exception/ Correction

### [Exception]

Exception is the cases of the buildings that do not comply with MRs but are structurally safe as per NBC 105 including the cases mentioned in NBC.

The exceptional cases were drafted by the NRA technical standardization committee on the basis of seismic requirements following NBC 105.

Hence, when all required corrective measures have been completed the building can be approved for the subsequent tranche of the housing reconstruction grant.

### [Correction]

Correction is the corrective measures required to make newly constructed or under construction buildings compliant with the seismic resistance standard as per NBC 105.

The appropriate corrective measures can be carried out on any individual building which is missing earthquake resistant elements as per MRs and at any stage of construction. These measures were drafted by the NRA technical standardization committee on the basis of seismic requirements following NBC 105.

Hence, when all required corrective measures have been completed the building can be approved for the subsequent tranche of the housing reconstruction grant.

# 1.1 Site condition (treatment / retaining wall)

- The building site shall be safe to withstand natural hazards. Where there is evidence of inherent natural hazard in a locality, any existing buildings shall be studied to assess site conditions. Similarly, local practices used to manage such hazards, shall be judged based on the required level of acceptable risk. Areas which are susceptible to liquefaction during an earthquake should also be avoided.

## Problem

- Site selection shall be done so as to minimize risks in relation to natural hazards. No buildings shall be constructed in hazardous areas:

HAZARD AREA	Exception / Correction
Geological fault or Ruptured area	- Not to be evaluated for residential building
Water-Logged area River Bank	- Constructions is allowable, if the site is appropriately treated be undertaken . - Maintain minimum distance from river bank and observed high flood level.
Steep Slope	- If the terrain is stable and soil is medium to hard, construction on steep slopes is allowable.
Filled Area	- If a building is to be constructed on filled-ground, the foundation shall be deep enough so as to rest on the firm ground surface beneath the fill.
Rock-fall Area	- Building can be constructed in such areas except in risky rock fall area identified by geological study and local knowledge.



Step slope area



Constructed retaining wall

# 1. Site selection



## Solution

- Appropriate treatment of the site.
- Construction of retaining wall.

## Correction

Retaining walls should be constructed following the standards in the building code and related guidelines. Table 1 below provides some examples of masonry retaining walls.

Table 1. Masonry retaining walls to select for different conditions

TYPE	Dry stone	Banded dry stone	Cement Masonry	Gabion
Diagrammatic cross-section				
Top width	0.6~1.0m	0.6~1.0m	0.5~1.0m	1m
Base width	0.5~0.7H	0.6~0.65H	0.5~0.65H	0.6~0.75H
Front batter	Vertical	Varies	10 : 1	6 : 1
Back batter	Varies	Vertical	Varies	Varies
Nward drip Foundation	1 : 3	1 : 3	Horizontal or 1 : 6	1 : 6
Foundation depth Below draw	0.5m	0.5~1.0m	0.5~1.0m	0.5m
Range of height	1~3m	1~6m	1~8m	1~6m
Hill slope angle	<35°	<35°	<45°	<45°
General	Set stones along foundation bed. Use long band stones hand. Hand packed stones in back fills.	Cement masonry bands of 50cm thickness at 3m c/c. Other specifications as per dry stone wall.	Weep holes 15x15cm size at 1~2m c/c 50cm rubble backing for drainage.	Stones to be hand packed stone shape important. Blocky preferable to tabular.

\*Modified from IS 14458-1 [Guidelines for retaining wall for hill area, Part 1: Selection of type of wall].

\*See Mitigation Measures 1 for advice on how to construct retaining wall

P34 ~



## 2-1. Span of wall, Size of room, Height of wall

### Minimum Requirements

No.	Category	Sub-category	Description
2.	Shape of building	Clear span of wall	Not more than 12 times thickness of wall and not more than 4.5m.
		Size of room	Not more than 13.5sq.m.
		Height of wall	Floor height shall not be more than 3.0m.

### Problem

- Long or high unrestrained walls will deflect during earthquakes.
- Irregular shaped buildings will experience torsional effect during earthquakes.
- Complex shapes increase stress on parts of the building during earthquakes and will cause damage or failure.

### Common Defects

- Span of wall is more than 4.5m.
- Size of room is more than 13.5sq.m.
- Height of wall is more than 3.0m.



Span of wall is more than 4.5m



## 2. Shape of building

### Exception

- E1. The span of wall up to 12 times of wall thickness is acceptable in one direction, in case where wall thickness is more than 350mm.
- E2. The size of room is restricted to 13.5 sq.m only for those houses with RCC slab. The thickness of RCC slab should be 115mm -125mm.
- E3. The height of wall can be variable, if the wall thickness is more than 350mm and 230mm for stone and brick masonry respectively. However, the height to wall thickness ratio of a wall shall not be more than 1:8 for stone masonry and 1:12 for brick masonry.

### Solution

- Provide buttress wall with RCC band or wooden band with proper connection of buttress wall to existing wall. Use of buttress add strength and stiffness to long walls.
- Provide cross walls with R.C.C or wooden bands to divide the building into smaller spans.

### Correction

Span and size of room is more than in MRS



P35 ~ and P36 ~

\*See Mitigation Measures 2 and 3, for advice on how to construct buttress and cross wall

#### Adding buttress wall

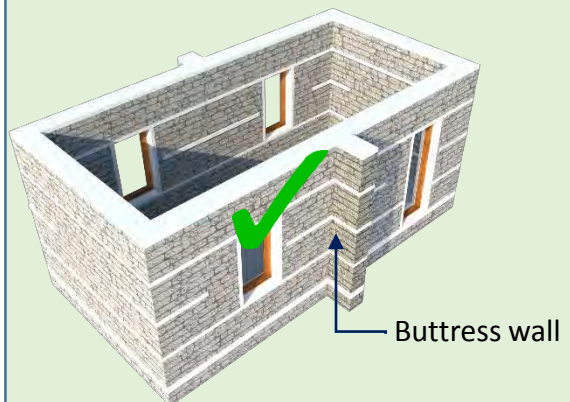

#### Adding cross wall

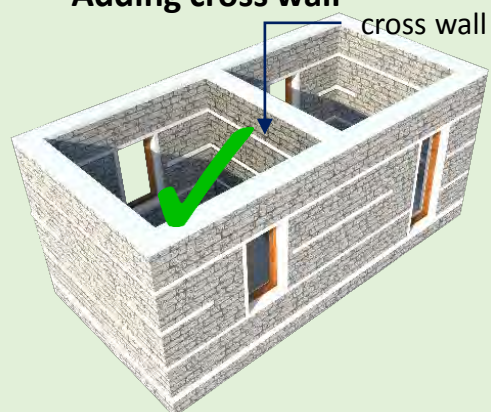

## 2.2 Shape of building (Proportion)

### Minimum Requirements

No.	Category	Sub-category	Description
2.	Shape and size of building	Proportion	Simple and regular shaped as square and rectangular shapes. The length of house shall not be more than 3 times of its width. Avoid setbacks.

### Problem

- Complex shapes increase the stress on parts of the building during earthquakes and will cause damage or failure.
- In order to minimize torsion motions, the building should be symmetrical and have a simple rectangular plan.

### Common Defects

- L,U and T shapes
- The length of house is more than 3 times of its width.



L shape



T shape



Long building



L shape

## 2. Shape of building

### Exception

- E1. The projected length up to (one fifth  $1/5$ ) of building length is acceptable, if all other requirements of MRs are fulfilled.
- E2. For small residential buildings not exceeding 100 sq.m. in plinth area with flexible floor and cross walls, the shape criterion of building can be ignored.
- E3. The cantilever-projection of roof/floor, where provided, shall not exceed 1m from center of wall. No load bearing walls shall be constructed over such cantilever-projections.
- E4. If the load bearing wall continues from ground floor to first floor on the same vertical line, vertical setback is allowable.

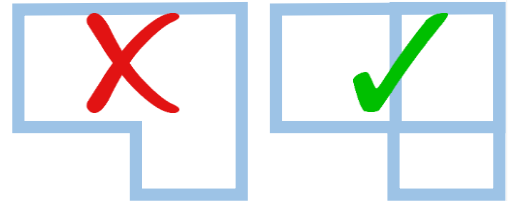

### Solution

- Provide expansion joint.
  - For preventing hammering or pounding damage between blocks, a physical separation of 40mm to 50mm throughout the height and above the plinth level shall be provided.

### Correction

#### Expansion joint for L-shape

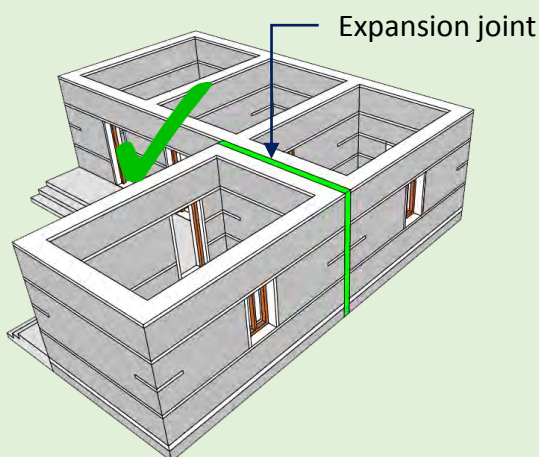

#### Expansion joint for long building

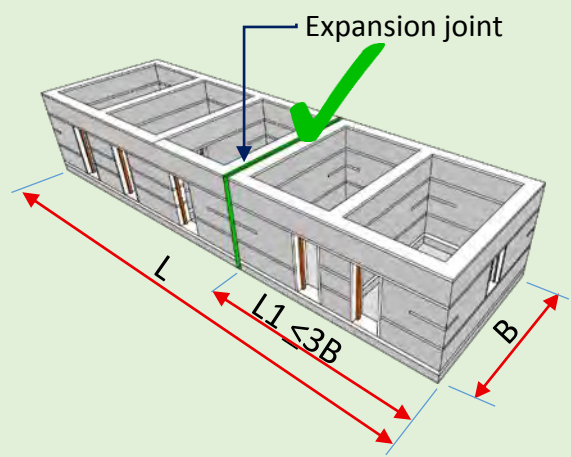



## 2.3 Number of Storey

### Minimum Requirements

No.	Category	Sub-category		Description	
2.	Shape of building	No. of storey	SMM/BMM	RC band	Not more than one plus habitable attic.
				Timber band	Not more than one storey.
			SMC/BMC	Not more than two plus attic	

### Problem

- Excessive storeys above the limits leads to high risk during an earthquake.

### Common Defects

- One storey plus attic constructed by stone masonry in mud mortar with wooden band.
- Two storeys constructed by stone masonry in mud mortar.
- Mix used of construction materials i.e. stone and mud mortar masonry ground floor and CGI and timber first floor.



Two storeys constructed by stone masonry in mud mortar.



One+Attic by stone masonry in mud mortar with wooden band



Mixed structure

P73~

\*See Options in ANNEX  
For advice on strengthen methods

## 2. Shape of building

### Exception

E1. If structure is found to be safe after structural calculation.

### Solution

- Demolish storeys above the limits prescribed in MRs.
- In case of one storey and attic in SMM or BMM with wooden band, provide RC roof band or provide gabion wire mesh or wooden members connecting the roof band to lower level band (floor band or lintel band)

### Correction

One storey plus attic constructed by stone masonry in mud mortar with wooden band.

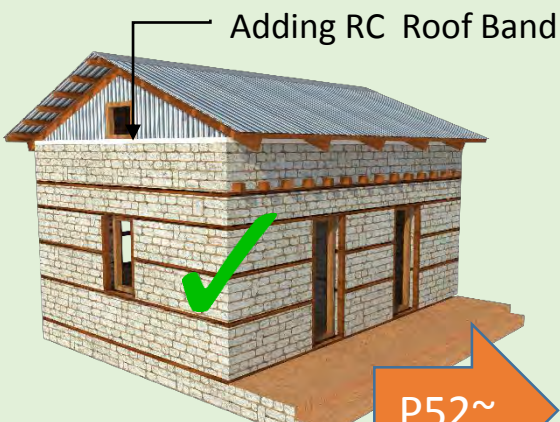
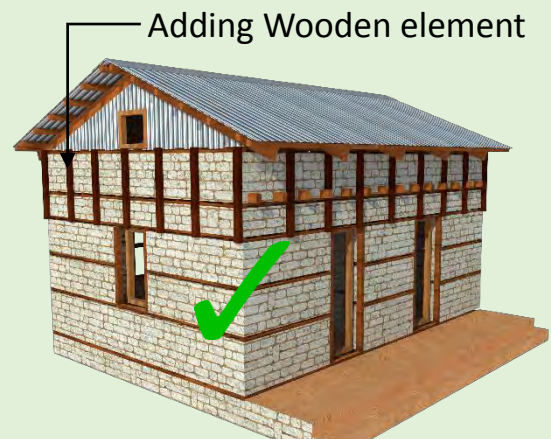

P52~

\*See Mitigation Measures 8  
For advice on construct horizontal band

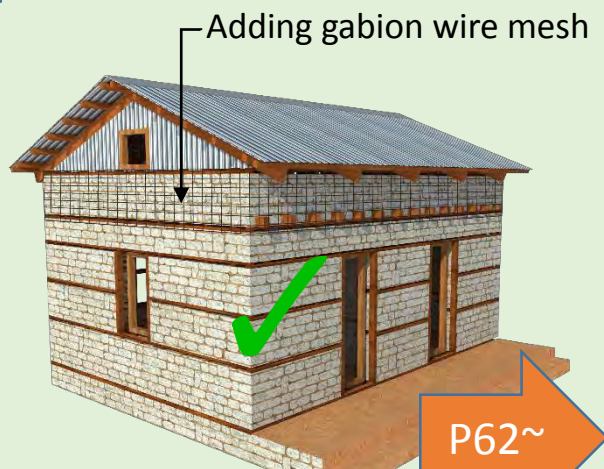

P62~

\*See Mitigation Measures 11  
For advice on strengthen the wall



## 3.1 Using improper materials, Mix materials

### Minimum Requirements

No.	Category	Sub-category	Description
3.	Materials	Stone	Avoid use of rounded, subrounded, easily breakable soft stone and boulder stones in its natural shape. River stone shall be dressed. Size of stone shall not be smaller than 50mm in thickness and 150mm in length or breadth.
		Brick	Over burnt, under burnt and deformed bricks shall not be used. Shall have minimum crushing strength of 3.5 Mpa for construction
		Timber	Well seasoned hard wood without knots shall be used for structural purpose. Timber treatment such as use of coal tar or any other preservative can prevent timber from being decayed and attacked by insects.

### Problem

- Load bearing masonry must have sufficient stability and strength to withstand lateral forces. Substandard walls may fail by cracking.
- Construction of walls or parts of the building in different materials results in poor connections.

### Common Defects

- Improper size of stone was used.
- Use of easily breakable soft stone and boulder stones as river stone in its natural shape.
- Mix-use of stone, brick, and concrete block.
- Use of untreated and soft wood in structural member.



Use of boulder stone



Mix-use of stone and brick for masonry wall



## Exception

- E1. The size of stone, used as fillers for proper bonding can be variable.
- E2. Well treated locally available wood can be used. The size of these wood shall be as per mentioned in MRs.
- E3. Mix use of stone and brick is acceptable if there is proper connection between these materials.
- E4. Mix use of wooden and concrete band at different level is acceptable in mud masonry.

## Solution

- Treatment of wood
- Strengthen the weak masonry wall, using proper correction method.
- Provide jacking for masonry wall.

## Correction

\*Correction method for weak masonry walls is shown in section 7. about Wall. Jacketing for masonry walls is a potential correction method.

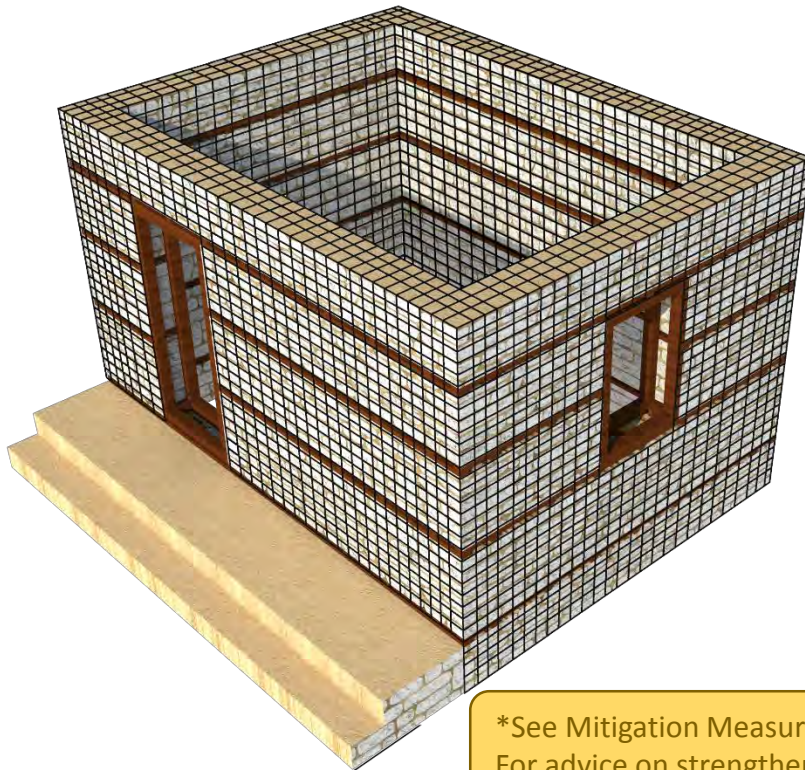

P62~

\*See Mitigation Measures 11  
For advice on strengthen the wall

# 4.1 Insufficient Foundation

## Minimum Requirements

No.	Category	Sub-Category	Description			
4	Foundation	General	It shall be continuous strip footing of uniform width at same level throughout the foundation in flat area. * If the building has to be constructed in existing foundation consult with expert.			
			Type of soil	One storey	Two storey	
		Depth of foundation below GL	SMM	All	> 750mm	-
			BMM	All	> 750mm	-
			SMC	All	> 800mm	> 900mm
			BMC	All	> 800mm	> 900mm
		Base width	SMM	Soft soil	> 800mm	-
				Medium soil	> 750mm	
				Hard soil	> 750mm	
			BMM	Soft soil	> 750mm	-
				Medium soil	> 650mm	
				Hard soil	> 550mm	
			SMC	Soft soil	> 800mm	Not recommended
				Medium soil	> 600mm	> 800mm
				Hard soil	> 600mm	> 600mm
BMC	Soft soil		> 650mm	> 900mm		
	Medium soil		> 550mm	> 650mm		
	Hard soil	> 550mm	> 550mm			

### Problem

- In order to transmit the load of the building to the ground uniformly, a proper foundation is required. Soft soil can cause more settlement and distortion during earthquakes.

### Common Defects

- No foundation
- Improper foundation



No foundation



Shallow depth of foundation



# 4. Foundation

## Exception

E1. Foundations size can be variable for hard rock bed. Here, proper levelling of foundation is required with proper anchorage of vertical element to the rock.

## Solution

- Excavate and provide additional foundation with proper connection with existing foundation.

\*Foundation correction is relatively difficult and should be carefully managed.

## Correction

- Insufficient Foundation.
  - Depth
  - Width
  - shape



### Additional external foundation

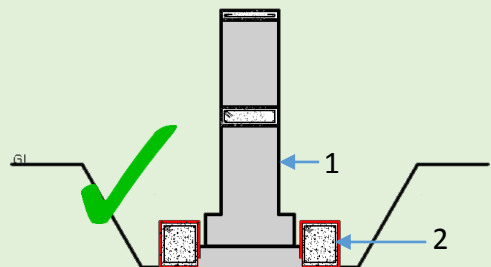
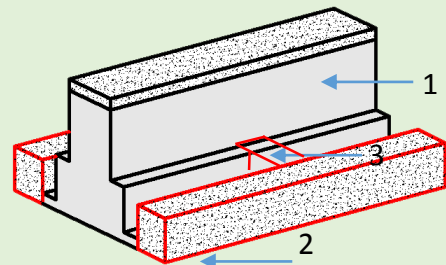

Vertical section of wall

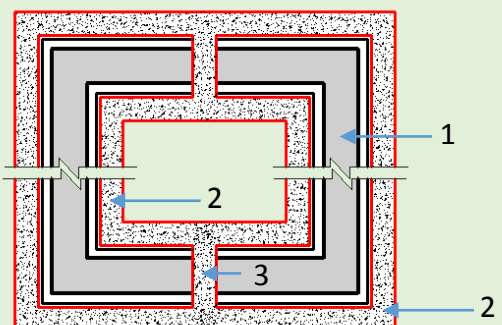

- 1- Old foundation
- 2- New concrete beams
- 3- Connecting lateral concrete beams

## 5.1 R.C Vertical Member

### Minimum Requirements

No	Category	Sub-category	Description
5	Vertical member	General	Shall be started right from the foundation and continue up to the roof band. Place vertical member at all corners, junctions of walls and adjacent to all doors and windows. Steel or timber can be used as vertical member.
		Reinforcement	RC
			At corners and junctions vertical reinforcing bar shall be 12mm for one storey, and 16mm for two storey . They shall be covered with concrete or 1:4 mortar in cavities made around them during the masonry construction.
Anchorage	Should be started right from the foundation and continue up to the band. In case of using existing foundation, it shall be anchored to plinth band. The anchorage length shall be 60 times diameter of the bar.		

### Problem

- Vertical reinforcement is used in masonry building to improve the integrity of the walls, to tie the walls together, and to tie the building from the foundation to roof band. Buildings with substandard or absent reinforcement are vulnerable during earthquakes.

### Common Defects

- Absence of reinforcement at corner and T-junction.
- Placement of reinforcement bars in incorrect positions.
- Size of reinforcement bars is different than MRs.
- Absence of vertical reinforcement bars at the side of openings.



Absence of reinforcement at corner and T-junction.



Vertical reinforcement provided at different location

# 5. Vertical Member

## Exception

- E1. 12mm diameter vertical reinforcement can be used in one storey and one plus attic building.
- E2. If total length, height and location of opening is appropriate as per MRs, reinforcement of opening can be ignored. (\*Height of opening should be less than 50% of wall height)
- E3. If the windows are provisioned with wooden double framed box and well connected to sill and lintel horizontal bands then vertical reinforcement around the windows can be ignored.

## Solution

- Provide RC vertical reinforcement(splint) on the wall wherever required and anchor them sufficiently with the wall.
  - Provide Welded GI wire mesh splint on the wall wherever required and anchor them sufficiently with the wall.
- \*In corner and T-junctions, RC vertical reinforcement(splint) can be provide only on outside.

## Correction

No RC vertical member.



Provide reinforcement member

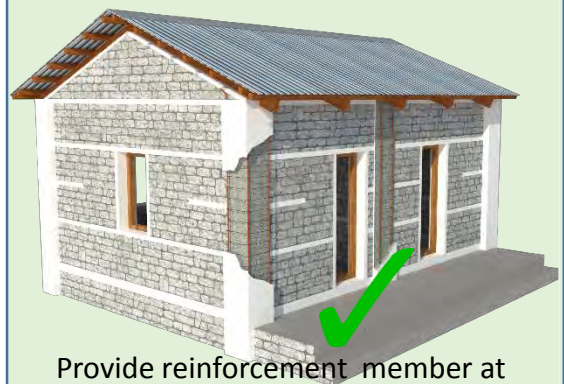

Provide reinforcement member at the outside



Provide bandage at the outside

P37~

\*See Mitigation Measures 4 and 5  
For advice on installation RC vertical reinforcement and bandage

## 5.2 Wooden Vertical Member

### Minimum Requirements

No	Category	Sub-category	Description
5	Vertical member	General	Shall be started right from the foundation and continue up to the roof band. Place vertical member at all corners, junctions of walls and adjacent to all doors and windows. Steel or timber can be used as vertical member.
		Reinforcement	Hard wood. One member of 75mm x 100mm for corner. Two member of 75mm x 100mm for openings

### Problem

- Vertical reinforcement is used in masonry building to improve the integrity of the walls, to tie the walls together, and to tie the building from the foundation to roof band. Buildings with substandard or absent reinforcement are vulnerable during earthquakes.

### Common Defects

- Absence of vertical wooden members at corner and T-junction
- Placement of vertical wooden members in incorrect positions.
- Size of wooden members is different than as per MRs.
- Use of untreated soft wood.



Absence of Vertical member



Vertical band provided in different locations



# 5. Vertical Member

## Exception

- E1. If total length, height and location of opening is appropriate as per MRs, vertical members of openings is not restricted. (\*Height of opening should be less than 50% of wall height)
- E2. If the openings are provisioned with wooden double framed box and properly connected to horizontal bands then vertical members around the openings as well as can be ignored.



Wooden double framed box

## Solution

- Place vertical member at the inside or outside corner of the wall.
- Use double framed box windows or doors instead of reinforcement of side of openings.

## Correction

No Vertical member

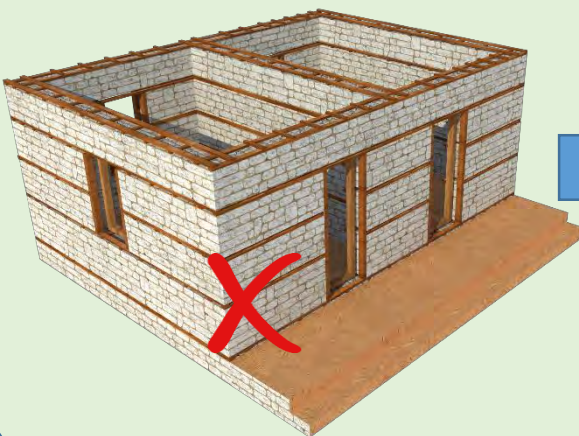

### Installation of vertical member

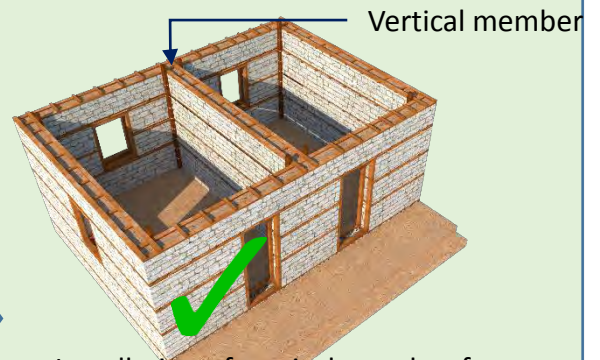

Installation of vertical member from inside of the wall

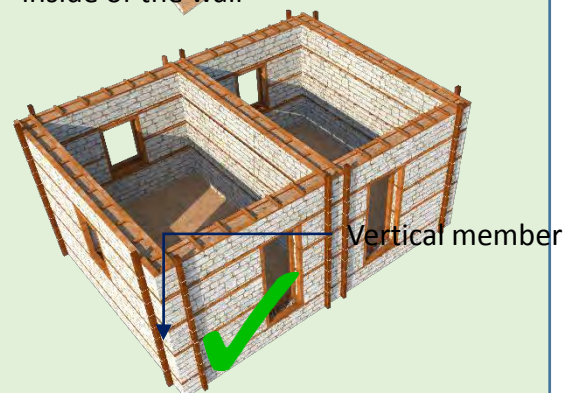

Installation of vertical member from outside of the wall

P46~

\*See Mitigation Measures 6  
For advice on installation wooden vertical member

# 6.1 No Plinth beam / Level of Plinth

## Minimum Requirements

No	Category	Sub-category	Description
6	Plinth	General	The level of plinth shall not be less than 300mm from ground level.

### Problem

- An unequal or loosely packed plinth will not provide a base of sufficient stability during an earthquake.
- Rotten timber in structural members will fail during an earthquake. Timber should be keep away from contact of moisture.

### Common Defects

- Absence of plinth band
- Level of plinth is less than 300mm from ground level.



Absent of plinth beam



Absent of plinth beam



Level of plinth is less than 300mm from ground level

PART-A: Exception / Correction



# 6. Plinth Beam

## Exception

E1. The height of plinth level can be changed as per site condition such as surrounding road level, rainfall intensity of area, drainage condition etc.

## Solution

- If the plinth band is missing, provide external plinth band on the wall with proper connection.
- If the height of plinth is less than 300mm,
  - Improve site drainage and provide apron.
  - Increase ground floor level.
  - Provide Damp proofing course.

\*Wooden band should be protected from ground water, rainwater and contact of moisture .

## Correction

For no plinth beam  
Provide external plinth band

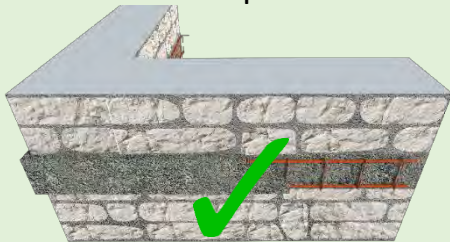

\*same methods as additional horizontal band.



\*See Mitigation Measures 8 and 9  
For advice on construct horizontal band

For low level of Plinth  
Improving site drainage

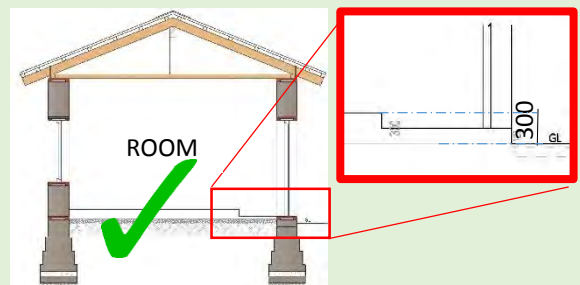
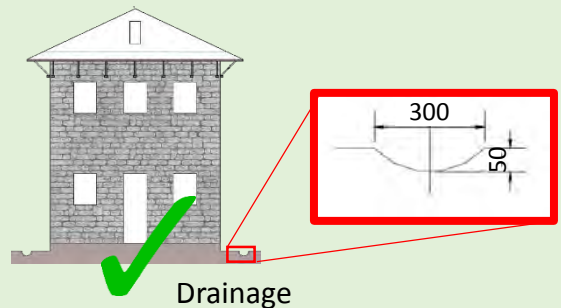

Increasing floor level

## 7.1 Weak masonry / Lack of Through stone

### Minimum Requirements

No.	Category	Sub-category	Description	
7	Walls	General	Masonry shall not be laid staggered or straggled in order to avoid continuous vertical joints. At corners or wall junctions, through vertical joints shall be avoided by properly laying the masonry. It shall be interlocked.	
		Thickness	SMM	Not less than 350 to 450mm for one storey.
			BMM	Not less than 350mm.
			SMC	Not less than 450 mm.
			BMC	It shall not be less than 230mm for one-storey, 350 and 230mm for ground floor and first floor of two-storey respectively.
		Joints	Mortar joints shall not be more than 20mm and less than 10mm in thickness.	
Through stones	Through-stone of a length equal to the full wall thickness shall be used in every 600 mm height at not more than 1.2 m apart horizontally.			

### Problem

- load bearing masonry must have sufficient stability and strength to withstand lateral forces. Substandard walls may fail by cracking.
- During earthquakes, delamination of wall is caused due to the absence of through stone and overuse use of small stones.
- Construction using mixed materials for the wall may result in poor connections and requires additional detailing to tie the building together.



Delamination of wall

### Common Defects

- Weak masonry using low quality of material.
- Absence of through stone and horizontal or vertical distance of through-stone is inappropriate.
- Mix of materials used in masonry walls.



Mix of materials used in masonry walls



## Exception

- E1. If full-length stones are not available, pairs of stones, each not less than three quarters of the wall thickness long shall be used in place of one full-length stone so as to provide an overlap between them.
- E2. Alternatively, seasoned wooden dowels or precast concrete or in-situ concrete or steel hooked link or S-shaped tie can be used instead of through stones.

## Solution

- Insert through stone or connector at the required spacing.
- Strengthen the weak masonry wall, using appropriated correction method, for example jacketing method for masonry walls.

## Correction

### For absence of through stone

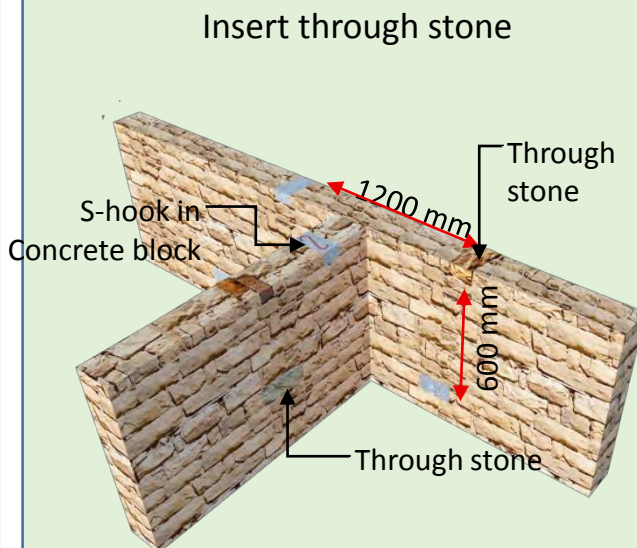

### For weak masonry

#### Jacketing for masonry wall

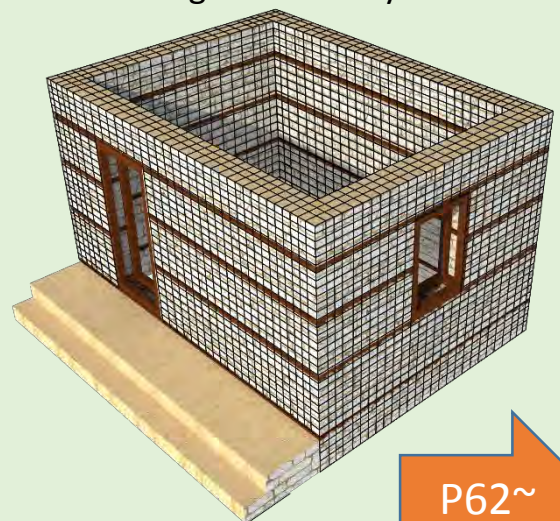

\*See Mitigation Measures 11  
For advice on strengthen the wall

**\*Correction measure  
are advisory only .**

## 7.2 Vulnerable Gable wall

### Minimum Requirements

No.	Category	Sub-category	Description
7	Walls	Gable wall	Provide light gables using wood, CGI sheets etc.

### Problem

- Gable masonry walls causes unbalanced mass in the building. During earthquake this masonry is highly vulnerable as it is not restrained.



Damage of stone masonry gable wall

### Common Defects

- Unsupported masonry gable wall.



Unsupported gable wall



Unsupported gable wall

## Exception

E1. Masonry gable wall with gable RC band is acceptable, if all other requirement of MRs are fulfilled. However, it is efficient to replace gable masonry wall with a truss covered with light weight materials.

## Solution

- Replace the gable masonry wall with light weight material.
- Provide additional RC gable band over gable wall and connect it with the roof truss.

## Correction

Light weight material used.

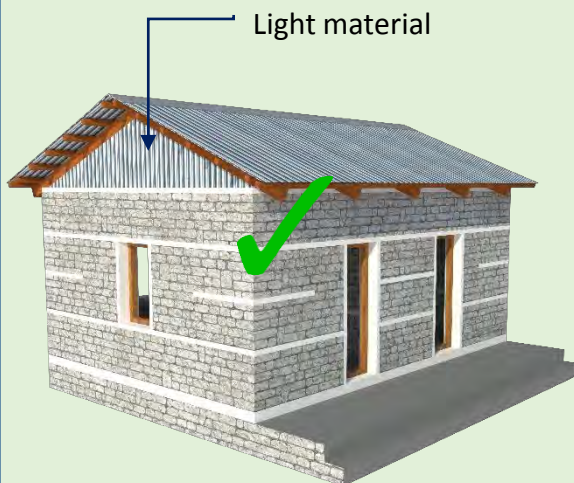

Additional reinforcement band over gable.

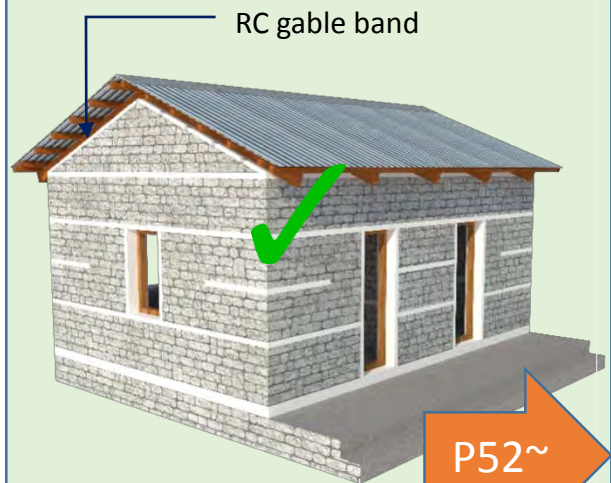

P52~

\*See Mitigation Measures 8 and 9  
For advice on construct horizontal band



# 8.1 Inappropriate Position and Size of Openings

## Minimum Requirements

No.	Category	Sub-category	Description	
8	Doors / windows.	General	Keep lintel level same for all doors and windows. Openings are to be located away from inside corners by a clear distance equal to at least 1/4 of the height of the opening, but not less than 600 mm.	
		Total length	SMM/BMM	The total length of openings in a wall is not to exceed 30 % of the length of the wall between consecutive cross-walls in single-storey construction.
			SMC/BMC	The total length of openings in a wall is not to exceed 50 % of the length of the wall between consecutive cross-walls in single-storey construction, 42 % in two-storey construction.
		Distance	The horizontal distance between two openings is to be not less than one half of the height of the shorter opening, but not less than 600 mm.	

### Problem

- Openings reduce the strength and stability of the wall.
- Openings too close to each other and to the corner reduce the overall strength of masonry.

### Common Defects

- Lintel level of opening is different.
- Percentage of opening is greater than its allowable.
- Position of opening is different than as per MRs.



Opening attached to the edge



Distance between openings



Horizontal distance between the openings



Distance of opening from the wall corner

# 8. Door and Windows

## Exception

- E1. If vertical elements of side of opening is appropriate as per MRs, total length and location of opening can be ignored.
- E2. If wooden double framed door and window with appropriate connection with horizontal band are provided, position and size of openings can be variable.
- E3. If concrete wall is constructed between two opening, the horizontal distance less than 600mm is acceptable.
- E4. In case of projected walls to make Dalan, the wall along the orthogonal direction should be equal or more than two times of wall thickness with proper resistant elements.



wooden double framed window



Dalan

## Solution

- Strengthening opening itself (wooden double frame).
- Strengthening around openings, i.e. providing vertical reinforcement.

## Correction

Ratio of openings in the wall is too big

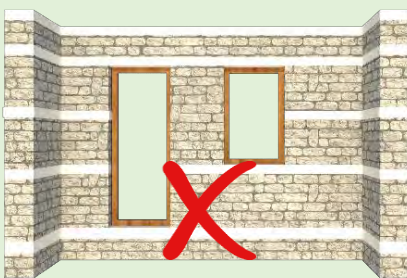

P48~

\*See Mitigation Measures 7  
For advice strengthening opening

### Replace openings

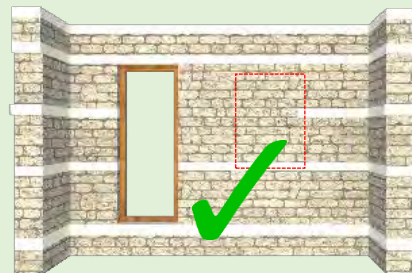

### Add vertical member

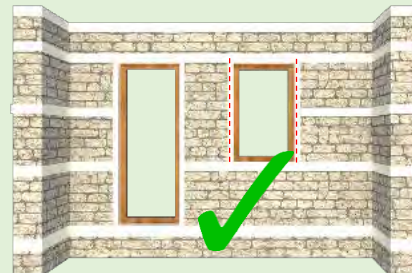

# 9.1 R.C. Horizontal band

## Minimum Requirements

No	Category	Sub-category	Description
9	Horizontal band	General	Horizontal bands shall be provided throughout the entire wall at plinth, sill, lintel, and roof level.
			RC band
		Sill band	A continuous sill band shall be provided through all walls at the bottom level of windows. The minimum thickness is 75mm.
		Lintel band	A continuous lintel band shall be provided through all walls at the top level of opening. Where opening width do not exceed 1.25m and masonry height above opening do not exceed 0.9m, 75mm lintel is sufficient. For opening width upto 2m and masonry height above opening upto 1.2m, 150mm lintel band is necessary.
		Stitch band	At corners and junctions, stitches( dowels) shall be provided addition at a vertical spacing of 500-700mm. The minimum length is 1.2m. The minimum thickness is 75mm.
Roof band	It shall be provided at the top-level of walls, so as to integrate them properly at their ends and fix them into the walls. The minimum thickness is 75mm.		

### Problem

- Horizontal bands are essential to tie the building together to act as a box. In absence of these bands, the building shall face in plane or out of plane failure.

### Common Defects

- Absence of horizontal band
- Insufficient reinforcement was used
- Discontinuous horizontal band .
- Insufficient thickness of band.
- Absence of reinforcement in RC band.



Absence of horizontal band and stitch



Inappropriate size of reinforcement



# 9. Horizontal Band

## Exception

- E1. If the floor height is less than or equal to 2.5m, the lintel band can be integrated with the floor / roof band.
- E2. If required amount of reinforcement with appropriate cover, as per MRs is provided thickness of band can be accepted within 10% tolerance, if all other requirement of MRs are fulfilled.

## Solution

- Provide external continuous RC horizontal bands on both faces of the wall.
- If lintel band is not provided, dismantle masonry above opening and construct a continuous lintel band.
- Provide Welded GI wire mesh bandages on both faces of wall wherever required and anchor them sufficiently with the wall

## Correction

No horizontal band



Installation of external horizontal band



External RC horizontal band



GI wire mesh bandages

P52~

\*See Mitigation Measures 8 and 9  
For advice on construct RC horizontal band

## 9.2 Wooden Horizontal Band

### Minimum Requirements

No.	Category	Sub-category	Description
9	Horizontal band	General	Horizontal bands shall be provided throughout the entire wall at plinth, sill, lintel, and roof level.
			Wooden band
		Sill band	Main wooden member, 2-75mmX38mm shall be placed along with wall and properly connected with batten, 50mmX38mm @ 500c/c.
		Lintel band	
		Stitch band	
		Roof band	
		Reinforcement	* Stitch (Mid band) shall be continuous.
Connection	Main wooden member shall be properly connected with 4 nails and batten with 2 nails. 5mm wooden nail or 3.15mm galvanized steel nail can be used.		

### Problem

- Horizontal band helps to tie the orthogonal wall together. If it is absent the building is more vulnerable to earthquakes.
- In plane and out of plane failure of wall might takes place in absence of horizontal wall.

### Common Defects

- Absence of horizontal band
- Insufficient size of wood was used
- Discontinuous sill and lintel band .



Absence of lintel band



Discontinuity of band



Absence of horizontal band



Absence of horizontal band



# 9. Horizontal Band

## Exception

E1. If the floor height is less than or equal to 2.5m, the lintel band can be integrated with the floor / roof band.

## Solution

- Provide horizontal wooden member from outer and inner wall and tie with GI wire, or provide RC and GI wire mesh bandage.

## Correction

No horizontal band

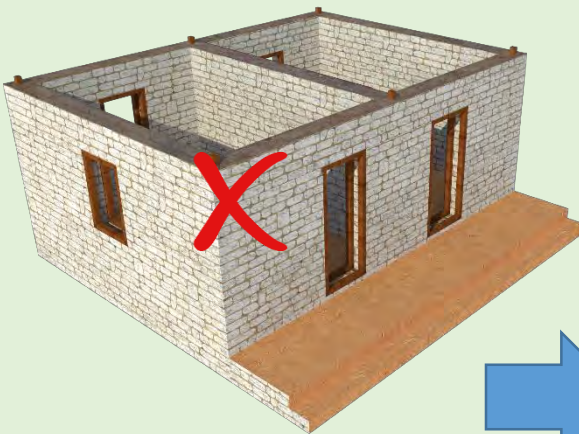

Installation of wooden external horizontal band



P60~

\*See Mitigation Measures 10  
For advice on construct Wooden  
horizontal band

# 10.1 Connection / Heavy Material for Roofing

## Minimum Requirements

No.	Category	Sub-category	Description
10	Roof	General	Use light roof comprising wooden or steel truss covered with CGI sheets.
		Connection	All members of the timber truss or joints shall be properly connected. Arrangements shall be done for connecting roof and wall.
		Bracing	For flexible diaphragm, diagonal bracings shall be considered.

### Problem

- The roof needs to be framed as a box to add stiffness to the main frame and to resist wind loads.

### Common Defects

- Use heavy weight material for roofing. (ex. slate stone, clay tile)
- Absence of connection between wall and roof



Slate stone roof



Clay tile roof

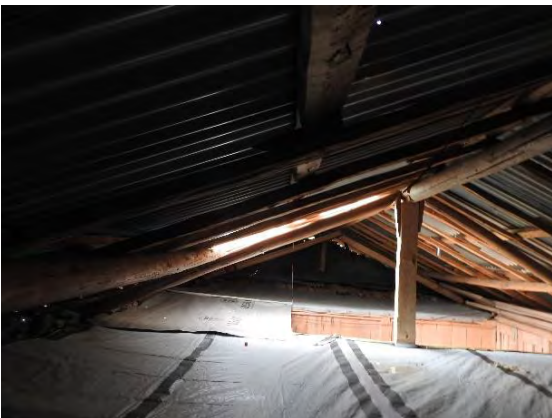

Connection of wooden truss



Connection of wooden truss

## Exception

E1. If structural details for fixing roof materials are found to be safe using locally available materials.

## Solution

- Using correct fixing for roofing materials.
- Connect the roof with the roof band by inserting reinforcement or GI sheet.
- Slatestone and clay tiles should be properly anchored to purlin as NBC.

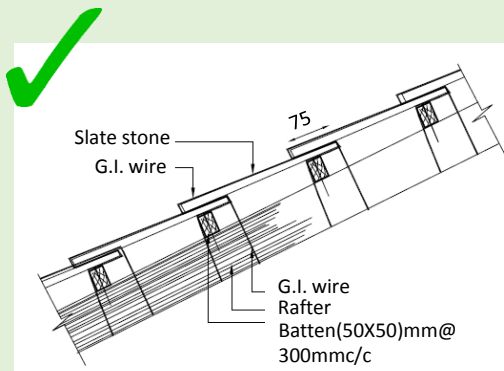

Detail of anchoring slate stone  
Source: NBC203 2015, P44

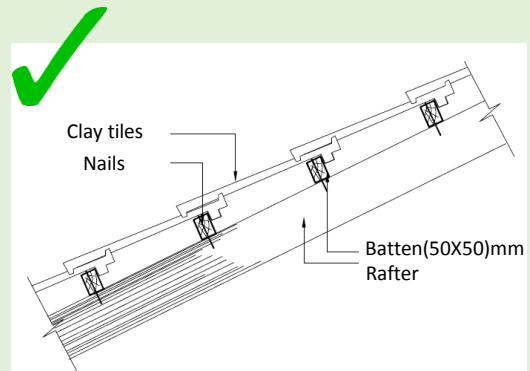

Detail of fixing clay tile  
Source: NBC203 2015, P45

## Correction

- Use a continuous wall plate, ridge and purlins to tie the rafters or trusses together.

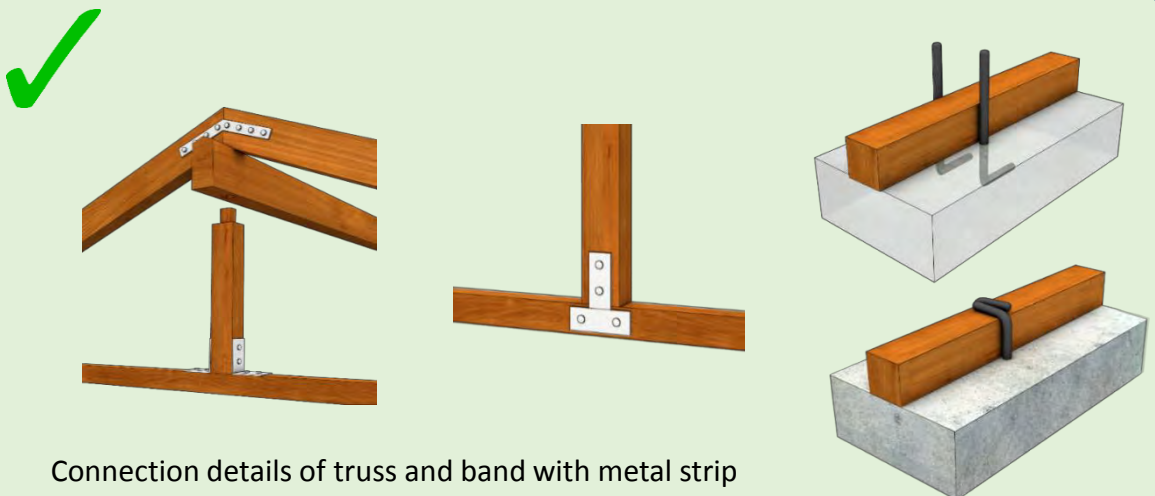

Connection details of truss and band with metal strip



## PART-B: Mitigation Measures

### [Mitigation Measures]

Different corrective measures has been introduced for the non-compliant issues, whereas some similar non-compliant issues can be solved by using different corrective measures. The Mitigation Measures consists of step by step procedure for implementing such correction. Depending upon the availability of materials and workmanship suitable Mitigation Measures can be adopted.



# 1. Construction of retaining wall

## Description

### Geometry: Slope

- The front face of the wall should be inclined at a slope of 1:5, either in a slope or in steps.
- The rear face should be vertical or slope parallel to the front face.

### Geometry: Dimension

- The base width of the wall should be minimum  $\frac{1}{2}$  of the retained height, ideally  $\frac{2}{3}$ <sup>rd</sup> of the retained height. The top of the wall should be 2 ft. wide.
- Terracing of the site can reduce the height of the wall and therefore the required width and total volume of masonry

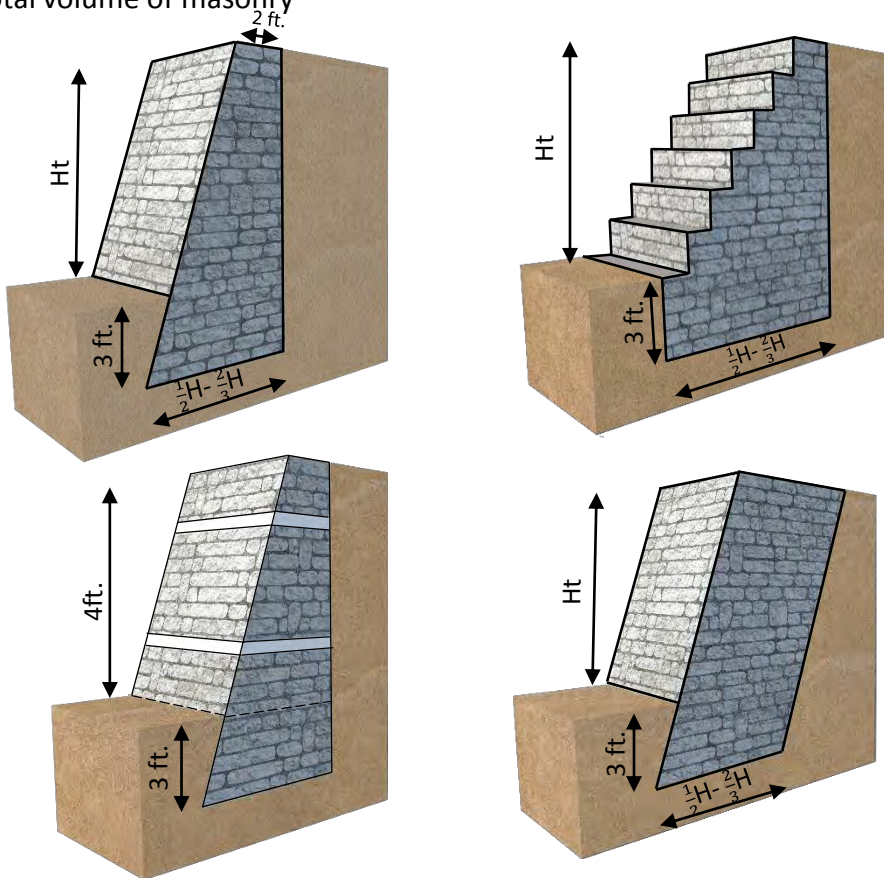

### Workmanship:

- Stones should be laid coursed, at an incline to the vertical, sloping downwards towards the retained slope.
- Stone should be placed tightly to ensure good interlocking and friction.
- Use flat field stones, do not use round stones. Mortar should not be a substitute for good masonry.
- Through stones, should be laid every 4ft. Vertically and horizontally, perpendicular to the length of the wall.

## 2. Strengthening wall with Buttressing

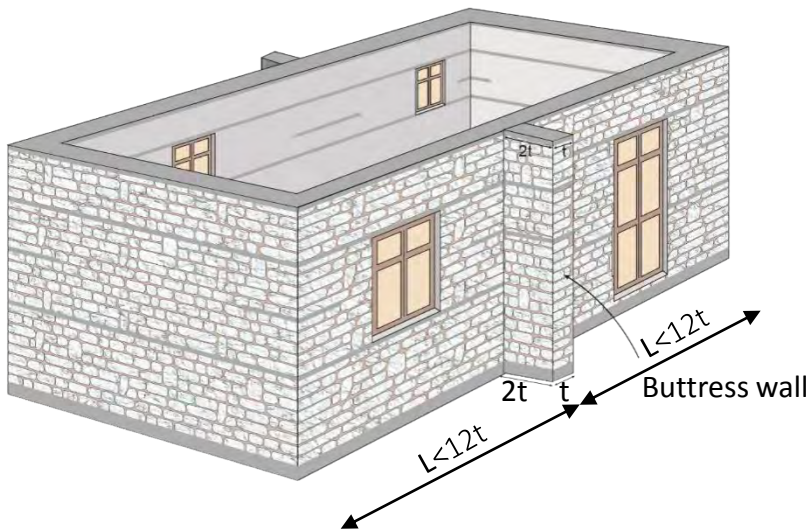

Addition of buttress wall when length of wall is greater than 12t

### RC horizontal band

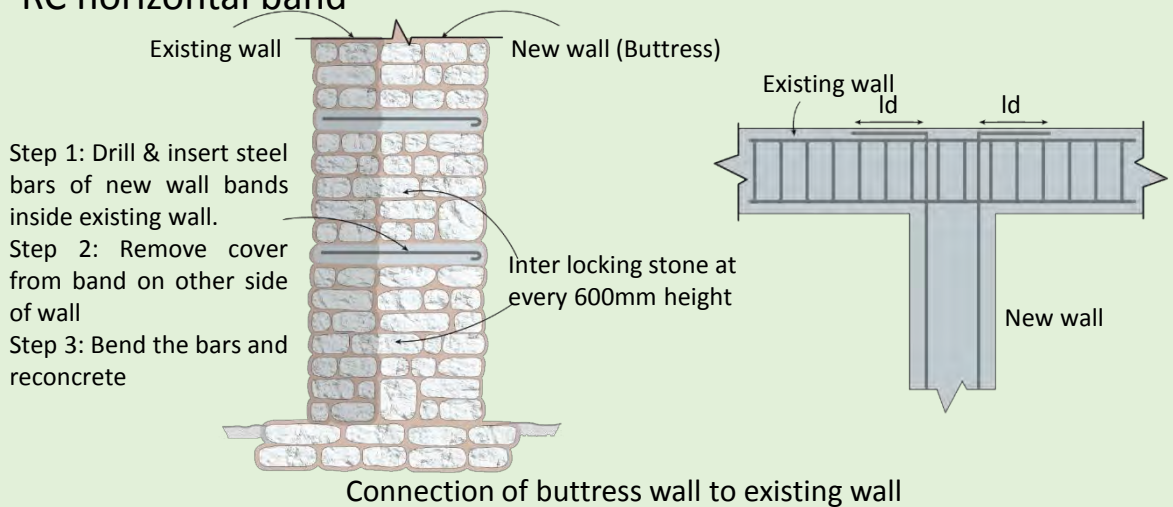

### Wooden horizontal band

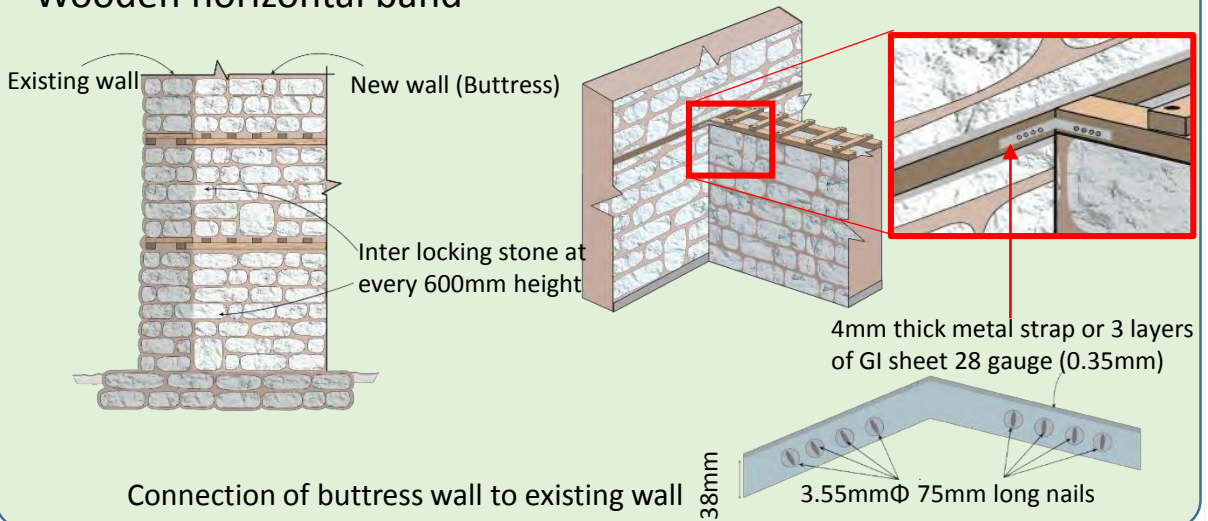

### 3. Adding Cross wall

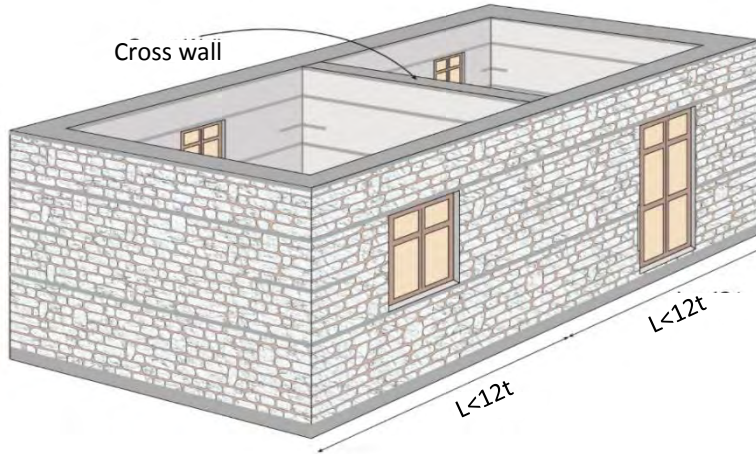

Addition of cross wall when length of wall is greater than 12t.

#### RC horizontal band

Existing wall      New wall (Cross wall)

Step 1: Drill & insert steel bars of new wall bands inside existing wall.  
 Step 2: Remove cover from band on other side of wall  
 Step 3: Bend the bars and re-concrete

Existing wall      New wall

Inter locking stone at every 600mm height

Connection of cross wall to existing wall

#### Wooden horizontal band

Existing wall      New wall (Cross wall)

Inter locking stone at every 600mm height

4mm thick metal strap or 3 layers of GI sheet 28 gauge (0.35mm)

38mm

3.55mm $\Phi$  75mm long nails

Connection of cross wall to existing wall



## 4. Installation RC vertical reinforcement

Provide RC vertical reinforcement(splint) as either Option I or Option II on faces of wall wherever required and anchor them sufficiently with the wall as shown in the following figures:

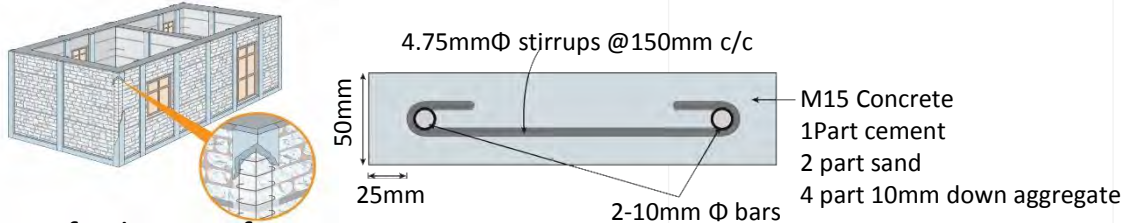

Addition of splints on faces of wall when vertical reinforcement is missing

Details of splints

### Option I : Round Shaped Random Rubble Masonry

At Corner

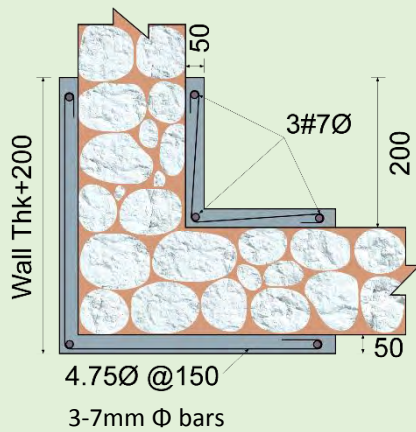

At T- Junction

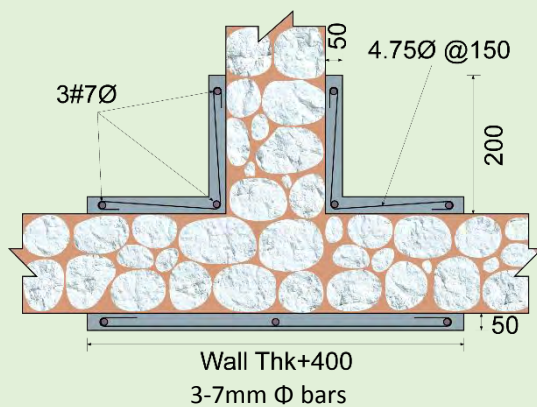

### Option II : Other Masonry, (except Option I)

At Corner

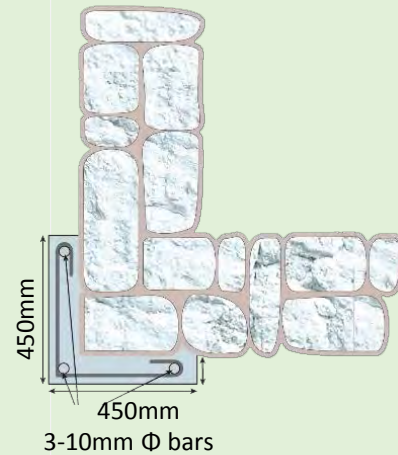

At T- Junction



Typical Details of splints

## 4. Installation RC vertical reinforcement

Note : Installation RC vertical reinforcement as per Option I is similar However, construction procedures for option II is more clearly presented in following pages.

too.

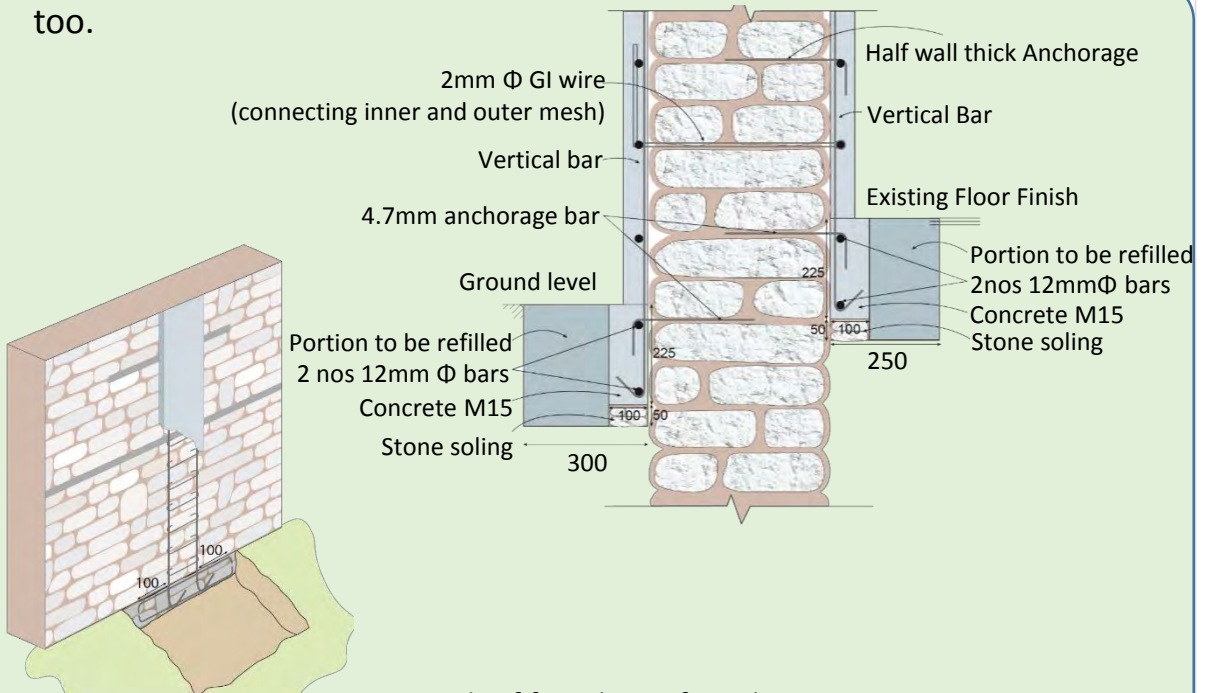



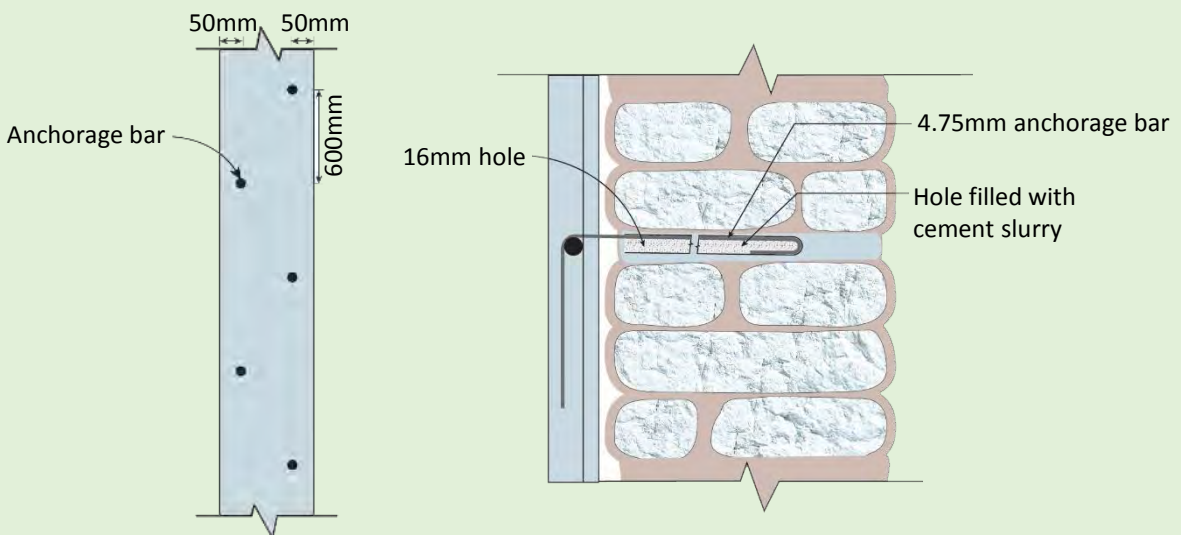

### Anchorage Details





## 4. Installation RC vertical reinforcement

### Construction procedure

Step	Description of work	Images
1.	<p><b>Surface Preparation</b></p> <ul style="list-style-type: none"> <li>Remove the plaster from the areas of the wall where bandages are to be placed.</li> <li>Rake out mortar upto a depth of ½"-1".</li> <li>Clean the surface, but don't use water for cleaning as mud mortar will be removed.</li> <li>Apply a thin layer of cement slurry on these areas.</li> </ul>	
2.	<p><b>Foundation Preparation</b></p> <ul style="list-style-type: none"> <li>Dig out trench for foundation as per suggested depth for placing tie beams for splints.</li> <li>Stone soling on the trench</li> </ul>	
3.	<p><b>Placing of reinforcement</b></p> <ul style="list-style-type: none"> <li>Place the horizontal bars in the trench</li> <li>Now, place vertical bars of splints</li> <li>Anchor them to the steel bar of trench</li> <li>Place stirrups on vertical bars</li> <li>(Note: Lapping of steel bars wherever required should be equal to development length:            4.75mm bar- 300mm lap            8 mm bar- 450mm lap            10 mm bar- 600mm lap            12 mm bar- 720mm lap            16 mm bar- 960mm lap)</li> </ul>	
4.	<p><b>Concreting of tie beam</b></p>	

## 4. Installation RC vertical reinforcement

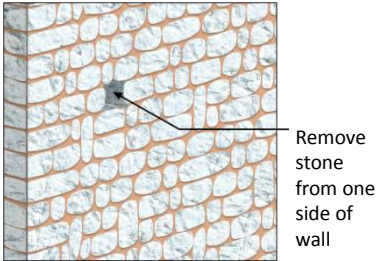

### Construction procedure

Step	Description of work	Images
5.	<p><b>Make holes for anchorage</b></p> <p>i) For through GI wire :</p> <ul style="list-style-type: none"> <li>• Make through holes in mud mortar on walls using steel rod and hammer at suggested locations.</li> <li>• Insert GI wires at suggested interval and location</li> <li>• When it is not possible to make a straight hole through the wall:               <ul style="list-style-type: none"> <li>- Remove stone on one side of wall, then insert a GI wire through the wall by bending it</li> <li>- Place the removed stone back into the wall using mortar</li> </ul> </li> </ul> <p>ii) For anchorage bar :</p> <ul style="list-style-type: none"> <li>• Make holes on one wyth of wall using steel rod and hammer.</li> <li>• Insert steel anchorage bars at suggested interval and location</li> <li>• When it is not possible to make a hole on wall:               <ul style="list-style-type: none"> <li>- Remove stone on one wyth of wall, then place anchorage bar</li> <li>- Place the removed stone back into the wall using mortar</li> </ul> </li> </ul>	 
6.	<p><b>Anchor reinforcing bar mesh</b></p> <ul style="list-style-type: none"> <li>• Fix reinforcing bars into the wall using inserted steel anchorage bars, jam the anchorage bar using cement slurry.</li> <li>• Connect inner and outer mesh using inserted through G.I. wires</li> </ul>	

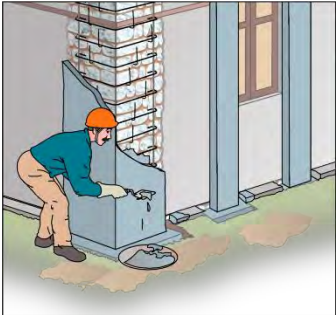

## 4. Installation RC vertical reinforcement

### Construction procedure

Step	Description of work	Images
7.	<p><b>Application of Micro Concrete</b></p> <ul style="list-style-type: none"><li>• Apply micro concreting on the reinforced splint and bandages with rich micro-concrete (M15) -20 to 25 mm thick in two layers. (Total thickness is 40-50mm)</li><li>• Micro concreting can be done by hand without shotcrete machine like in plastering.</li></ul>	 An illustration showing a construction worker in a blue shirt and orange hard hat applying a thick layer of micro-concrete to a wall. The worker is using a hand tool to spread the material. The wall has a grid of reinforcement bars visible. The floor is covered with a layer of concrete.
8.	<p><b>Curing of concrete</b></p> <ul style="list-style-type: none"><li>• Cure the concrete for 14days.</li><li>• Use jute bags/ mats for better curing</li></ul>	 An illustration showing a construction worker in a blue shirt and orange hard hat applying jute bags to a wall. The worker is holding a jute bag and applying it to the wall. A bucket of water is visible on the floor. The wall has a grid of reinforcement bars visible.

## 5. Installation GI mesh for splint

Provide GI Welded wire mesh splint on outer faces of wall wherever required and anchor them sufficiently with the wall as shown in the following figures:

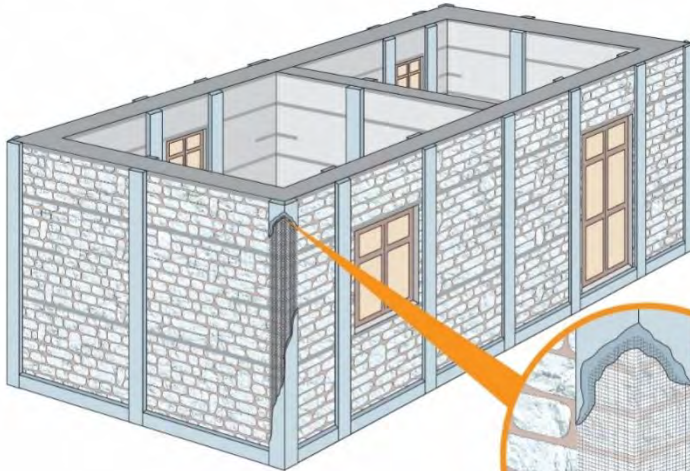

GI welded wire mesh

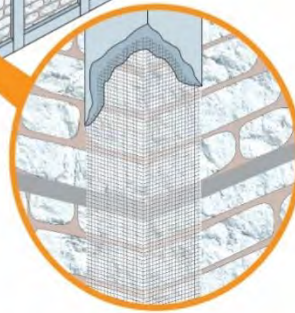

Addition of splints on outer faces of wall when vertical reinforcement is missing.

Corners

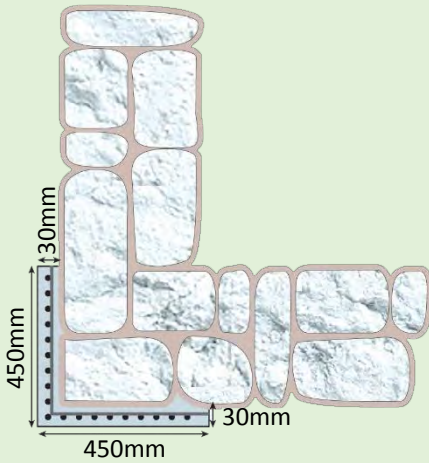

Junctions

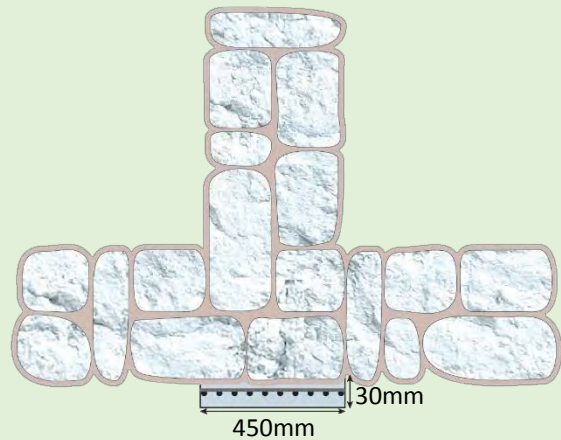

Welded GI wire mesh  
10 gauge (3.24mm)Φ bar @ 25mm c/c

1:3 cement sand plaster or  
stabilized mud mortar plaster

Details of splint





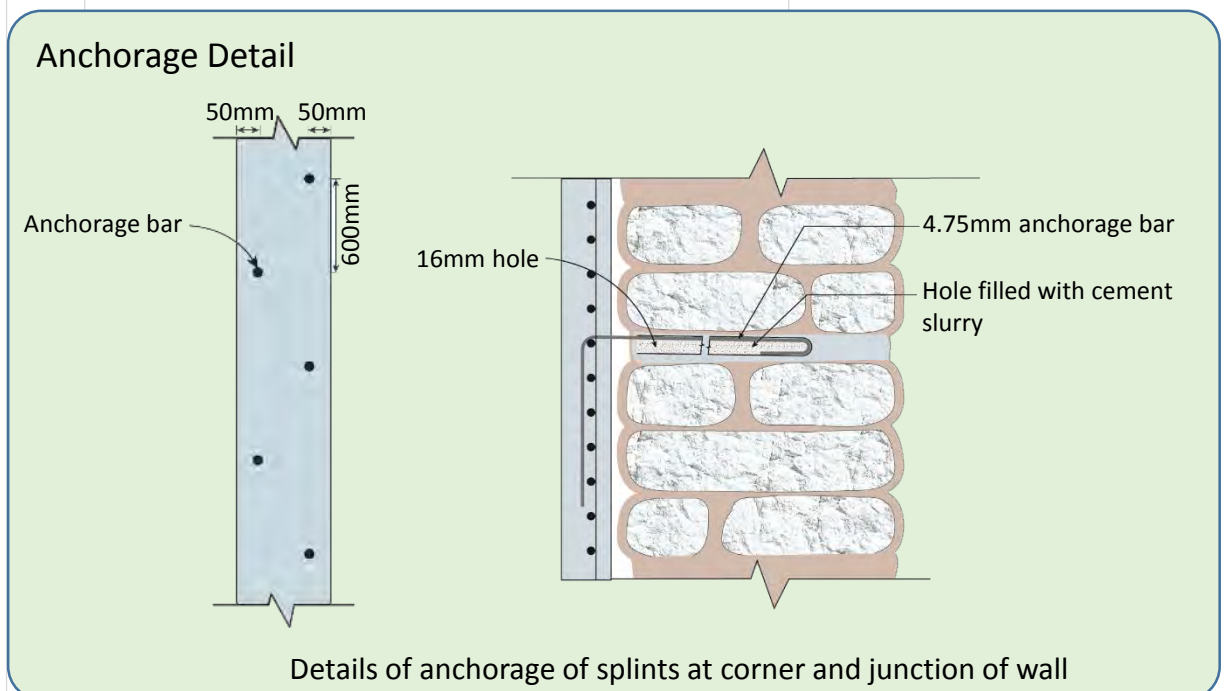
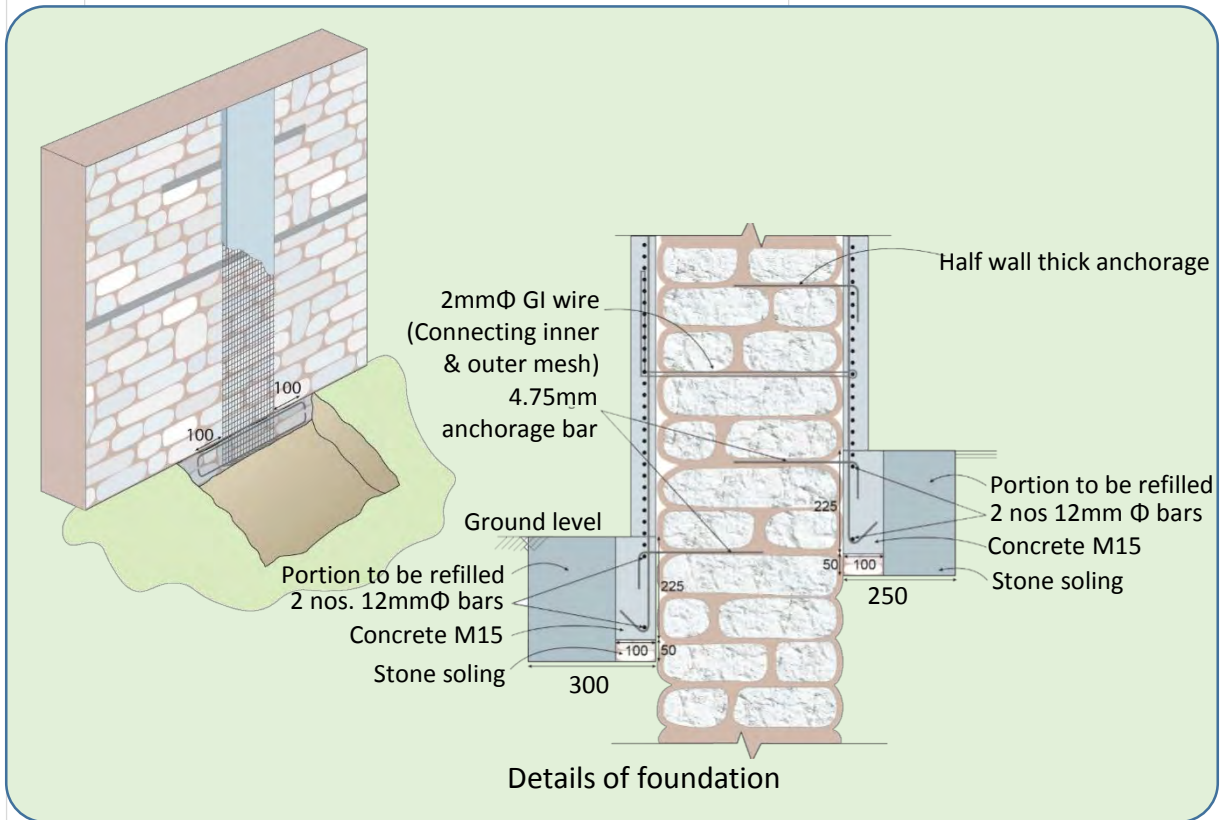

## 5. Installation GI mesh for splint





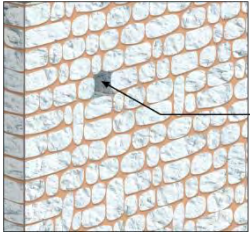

## 5. Installation GI mesh for splint

### Construction procedure

Step	Description of work	Images
1.	<p><b>Surface Preparation:</b></p> <ul style="list-style-type: none"> <li>Remove the plaster from the areas of the wall where bandages are to be placed.</li> <li>Rake out mortar upto a depth of ½"-1"</li> <li>Clean the surface, but do not use water for cleaning as mud mortar will be moved.</li> <li>Apply a thin layer of cement slurry on these areas.</li> </ul>	
2.	<p><b>Foundation Preparation:</b></p> <ul style="list-style-type: none"> <li>Dig out trench for foundation at suggested portion for placing tie beams for splints</li> <li>Stone soling on the trench</li> </ul>	
3.	<p><b>Make holes for anchorage</b></p> <p>i) For through GI wire:</p> <ul style="list-style-type: none"> <li>Make through holes in mud mortar on walls using steel rod and hammer at suggested interval and location.</li> <li>Insert GI wires at suggested interval and location</li> <li>When it is not possible to make a straight hole through the wall. <ul style="list-style-type: none"> <li>Remove stone on one side of wall, then insert a GI wire through the wall by bending it.</li> <li>Place the removed stone back into the wall using mortar.</li> </ul> </li> </ul> <p>ii) For anchorage bar:</p> <ul style="list-style-type: none"> <li>Make holes on one width of wall using steel rod and hammer.</li> <li>Insert steel anchorage bars at suggested interval and location</li> </ul> <p>When it is not possible to make a hole in the wall:</p> <ul style="list-style-type: none"> <li>Remove stone on one wyth of wall, then place anchorage bar.</li> <li>Place the removed stone back into the wall using mortar</li> </ul>	  <p>Remove stones from one side of wall</p>
4.	<p><b>Painting of GI wire mesh</b></p> <ul style="list-style-type: none"> <li>Welded GI wire mesh generally available in market are not galvanized properly, hence get corroded easily.</li> <li>Hence to prevent it from corrosion, paint it with Black Japan Paint or Bitumen emulsion paint</li> </ul>	



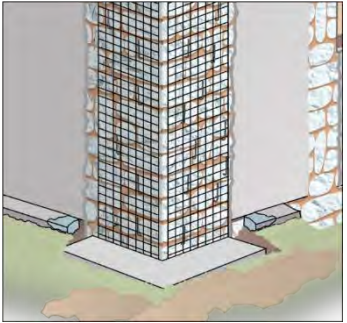

## 5. Installation GI mesh for splint

### Construction procedure

Step	Description of work	Images
5.	<p><b>Placing of GI wire mesh</b></p> <ul style="list-style-type: none"> <li>Place the horizontal bars in the trench</li> <li>Now, place vertical GI wire mesh of splints</li> <li>Anchor them to the steel bar of trench</li> </ul> <p>(Note: Lapping of mesh wherever required should be minimum 1 feet.)</p>	
6.	<p><b>Anchor GI wire mesh</b></p> <ul style="list-style-type: none"> <li>Connect inner and outer mesh using inserted through G.I. wires.</li> <li>Fix mesh into the wall using inserted steel anchorage bars, jam the anchorage bar using cement slurry.</li> </ul>	
7.	<p><b>Concreting of foundation beam</b></p>	
8.	<p><b>Plastering</b></p> <ul style="list-style-type: none"> <li>Apply 1:3 plaster about 1/2" thick in two layers. (Total thickness is 1")</li> </ul> <p style="text-align: center;">Or</p> <p>Apply stabilized mud mortar plaster if cement is not available</p>	
9.	<p><b>Curing of plaster</b></p> <ul style="list-style-type: none"> <li>In case of cement sand plaster, cure the plaster area for 7days.</li> <li>Use jute bags/ mats for better curing</li> </ul>	

## 6. Installation of wooden vertical member

### Construction procedure

Step	Description of work	Pictures
1.	<p><b>Surface preparation:</b></p> <ul style="list-style-type: none"> <li>Remove the plaster from the areas of the wall where reinforcements are to be placed.</li> <li>Rake out the mortar upto the depth of ½"-1".</li> <li>Clean the surface, but do not use water for cleaning as mud mortar will be removed.</li> <li>Apply a thin layer of cement slurry on these areas.</li> </ul>	
2.	<p><b>Make holes for anchorage:</b></p> <ul style="list-style-type: none"> <li>Make through holes in mud mortar on walls using steel rod and hammer at suggested location.</li> <li>Insert GI wires at suggested intervals and location.</li> <li>When it is not possible to make a straight hole through the wall:               <ul style="list-style-type: none"> <li>Remove stones on one side of the wall, then insert a GI wire through the wall by bending it.</li> <li>Place the removed stone back into the wall using mortar.</li> </ul> </li> </ul>	
3.	<p><b>Installation of vertical wooden member:</b></p> <ul style="list-style-type: none"> <li>Place 100mmX75mm vertical wooden member on either side of wall.</li> </ul>	
4.	<p><b>Anchor GI wire mesh:</b></p> <ul style="list-style-type: none"> <li>Connect the vertical wooden member with the wall using inserted GI mesh, jam the mesh using cement slurry or mud plaster.</li> </ul>	



## 6. Installation of wooden vertical member



Details of wooden diagonal bracing

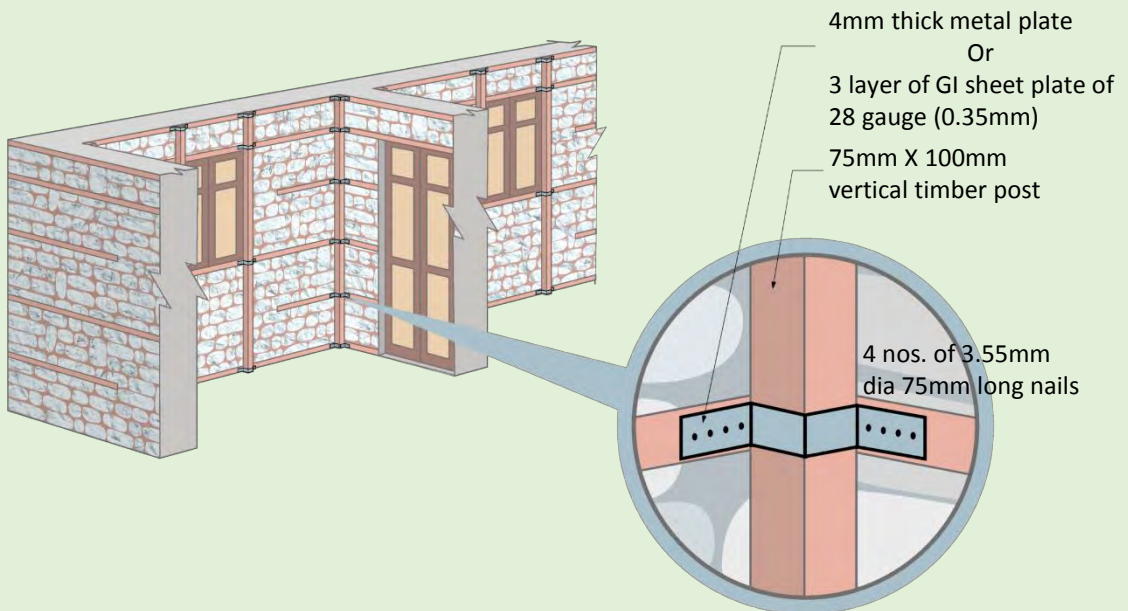

Details of connection of horizontal and vertical elements



# 7. Strengthen Opening

Option 1: Provide RCC splint on outer faces of wall wherever required and anchor them sufficiently with the wall.

## Openings

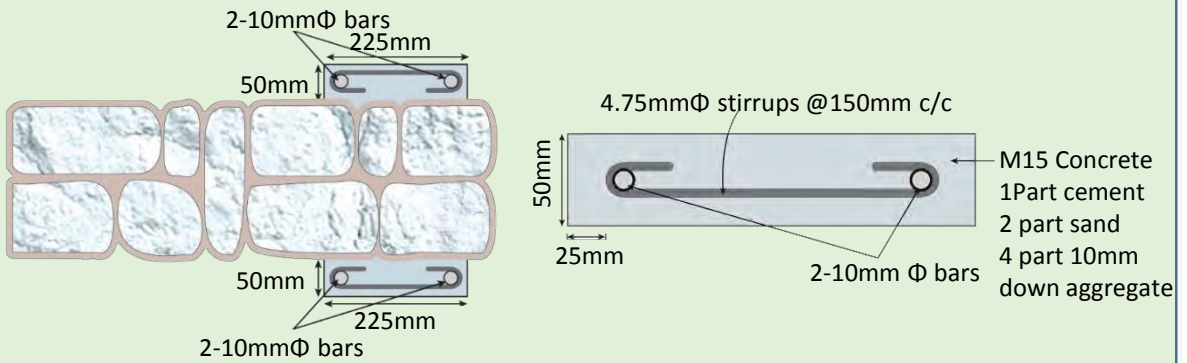

Details of splints around openings

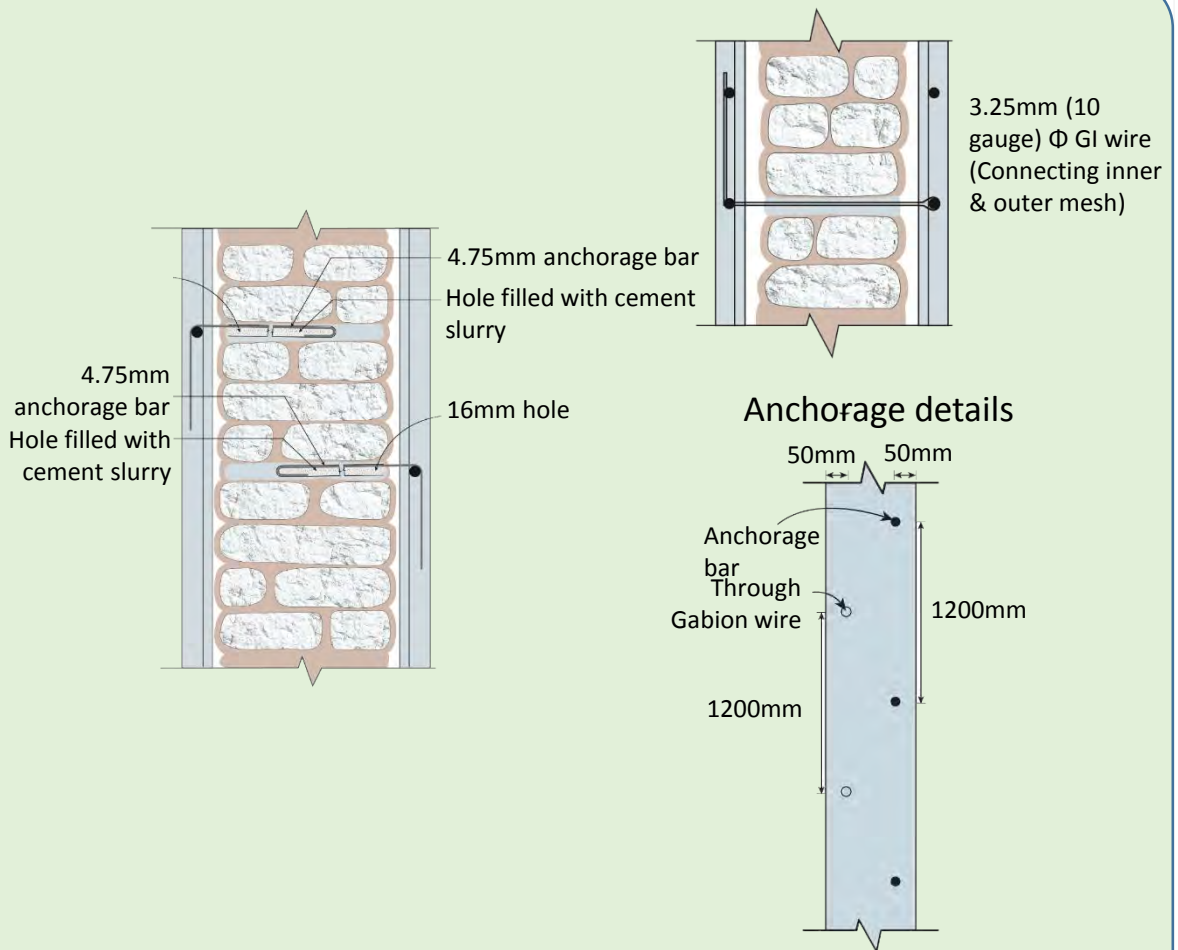

Details of anchorage of splints around openings

## 7. Strengthen Opening

Option 2: Provide Welded GI wire mesh splint on outer faces of wall wherever required and anchor them sufficiently with the wall.

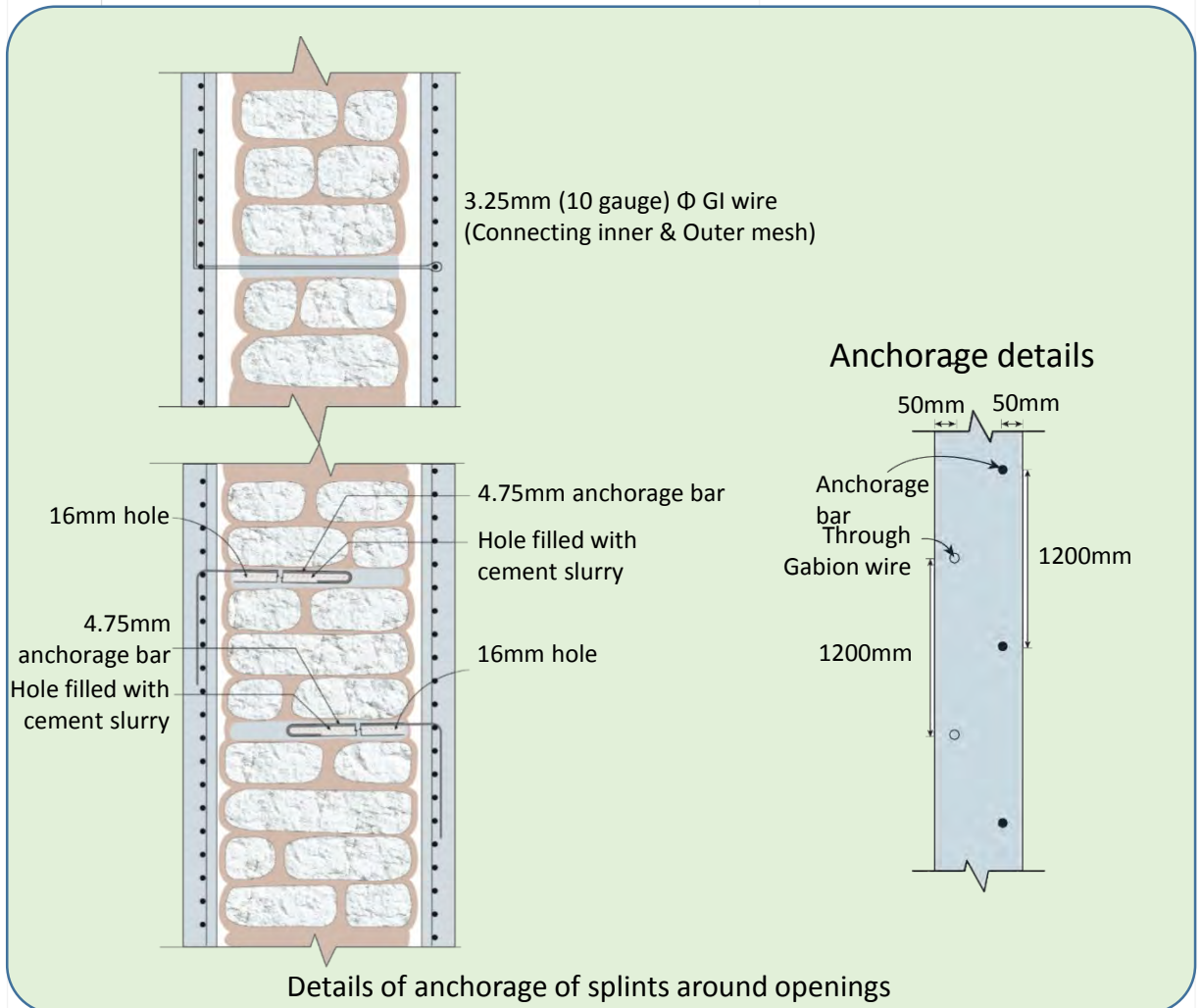
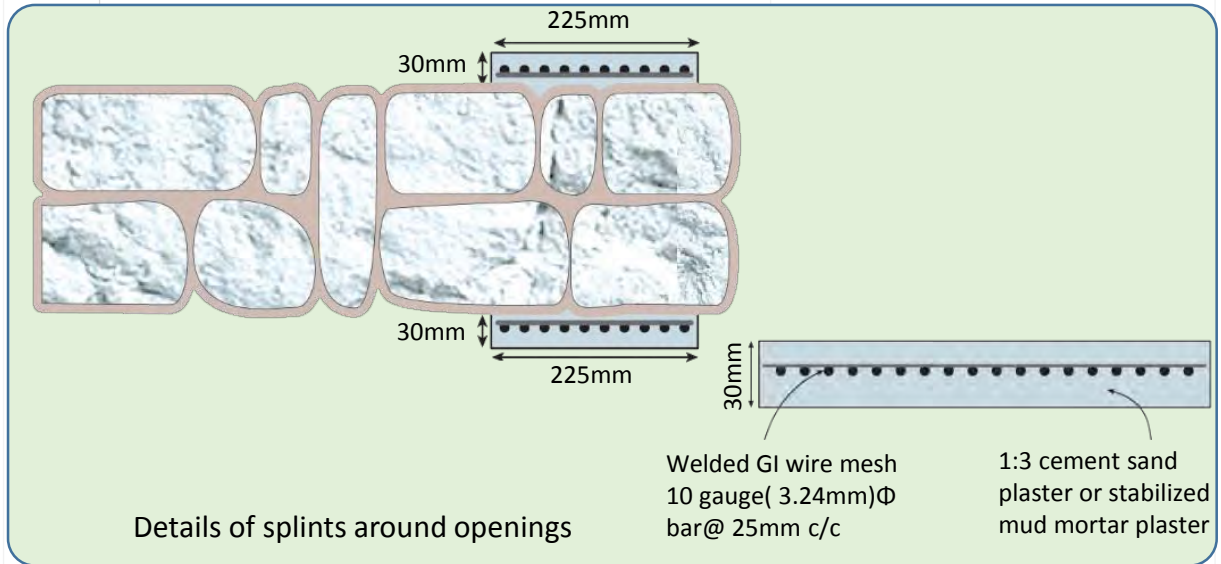

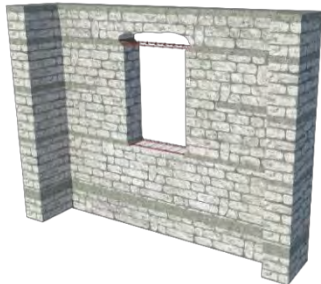
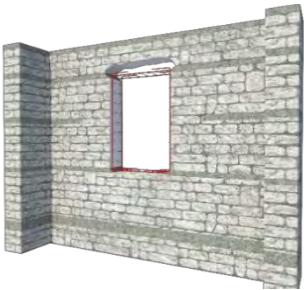
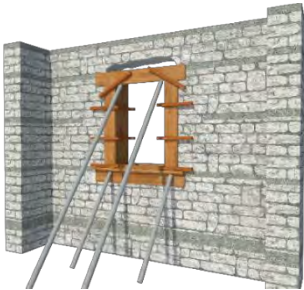
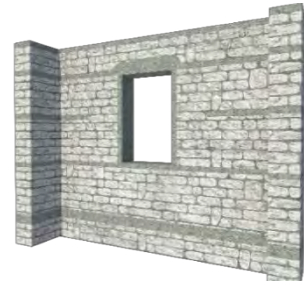

# 7. Strengthen Opening

## Construction procedure

Step	Description of work	Images
1.	<p><b>Surface preparation:</b></p> <ul style="list-style-type: none"> <li>Remove the plaster from the areas of the wall where reinforcements are to be placed.</li> <li>Prop the lintel and sill band for embedment of reinforcement.</li> <li>Rake out the mortar up to a depth of ½"-1".</li> <li>Clean the surface, but do not use water for cleaning as mud mortar will be removed.</li> <li>Apply a thin layer of cement slurry on these areas.</li> </ul>	
2.	<p><b>Installation of reinforcement:</b></p> <ul style="list-style-type: none"> <li>Install reinforcement bar for the vertical band.</li> <li>The diameter of the bar should be as per the MRs</li> <li>Place the removed stone back into the wall using mortar.</li> </ul>	
3.	<p><b>Installation of formwork:</b></p> <ul style="list-style-type: none"> <li>Install the formwork for the vertical band and pour concrete.</li> <li>Short Crete an be used wherever feasible.</li> </ul>	
4.	<p><b>Curing:</b></p> <ul style="list-style-type: none"> <li>Cure the freshly laid concrete for 10 days.</li> <li>Use jute bags/mats for better curing</li> </ul>	

# 7. Strengthen Opening

## Construction procedure

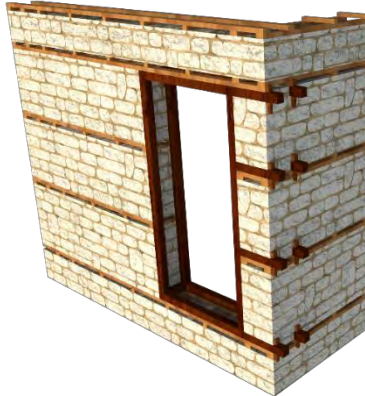
Step	Description of work	Images
1.	<p><b>Surface preparation:</b></p> <ul style="list-style-type: none"><li>• Clean the surface, but do not use water for cleaning as mud mortar will be removed.</li><li>• Take back the wall from around the opening</li></ul>	
2.	<p><b>Installation of wooden member:</b></p> <ul style="list-style-type: none"><li>• Install the wooden batten to make the connection between the opening frame and wall.</li><li>• Connect the member and opening with steel plate and nails.</li></ul>	
3.	<p><b>Connection:</b></p> <ul style="list-style-type: none"><li>• Connect the wooden member and the external wall with the wooden key</li></ul>	



## 8. Adding RC Horizontal band

Option 1: Provide RC horizontal bands on both side of wall on outer faces wherever required as shown in the following figures:

When it is not possible to transport concrete and steel to the site:

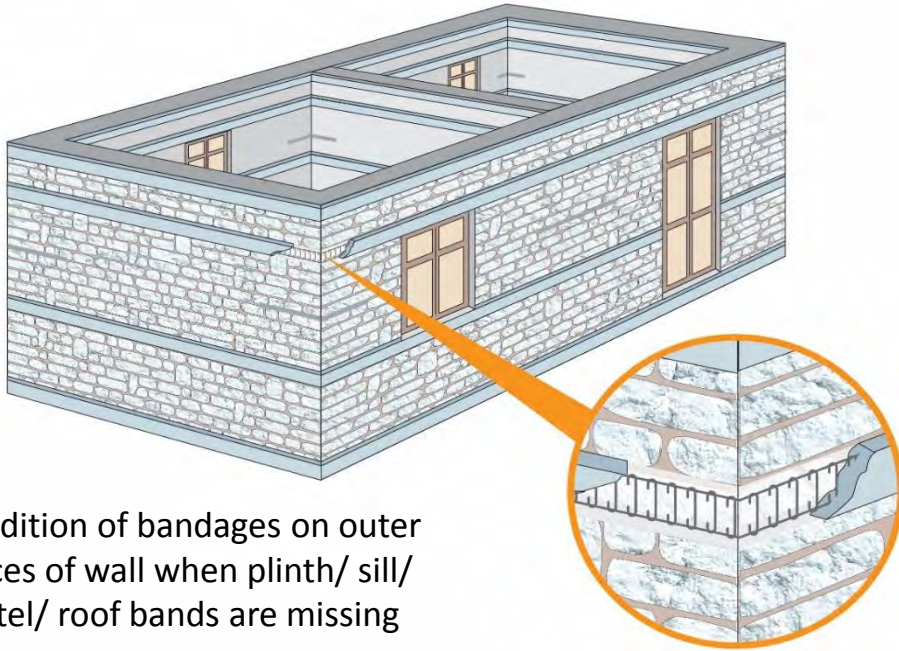

Addition of bandages on outer faces of wall when plinth/ sill/ lintel/ roof bands are missing

3.25mm(10 gauge)  $\Phi$ GI wire  
(Connecting inner & outer mesh)

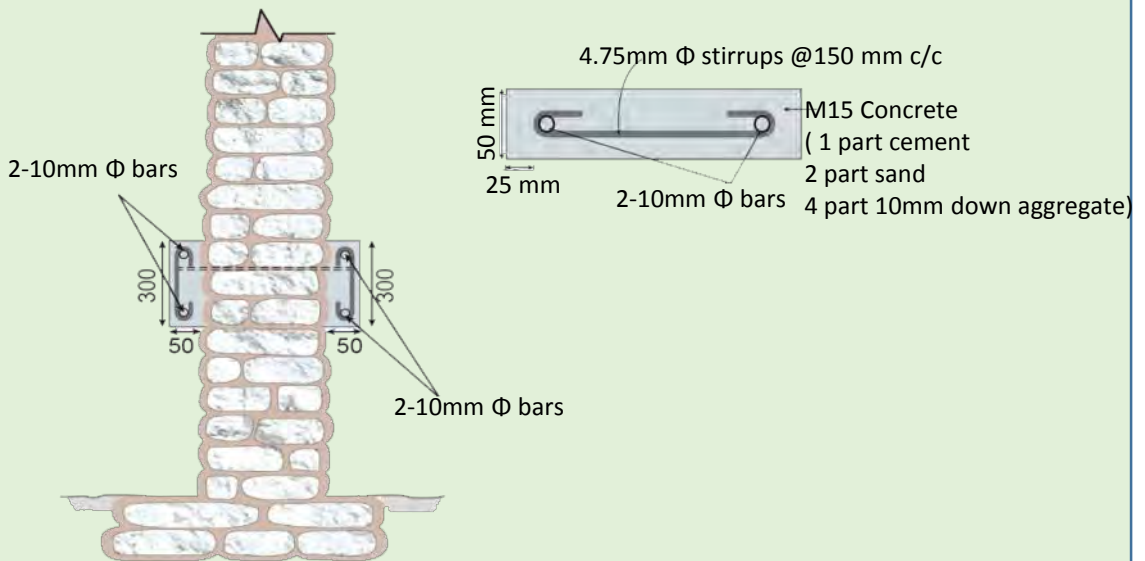

Details of additional horizontal band

## 8. Adding RC Horizontal band

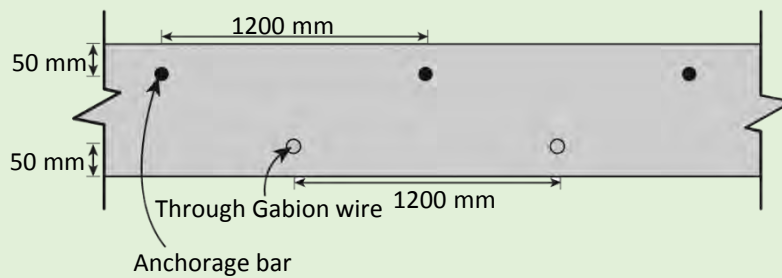
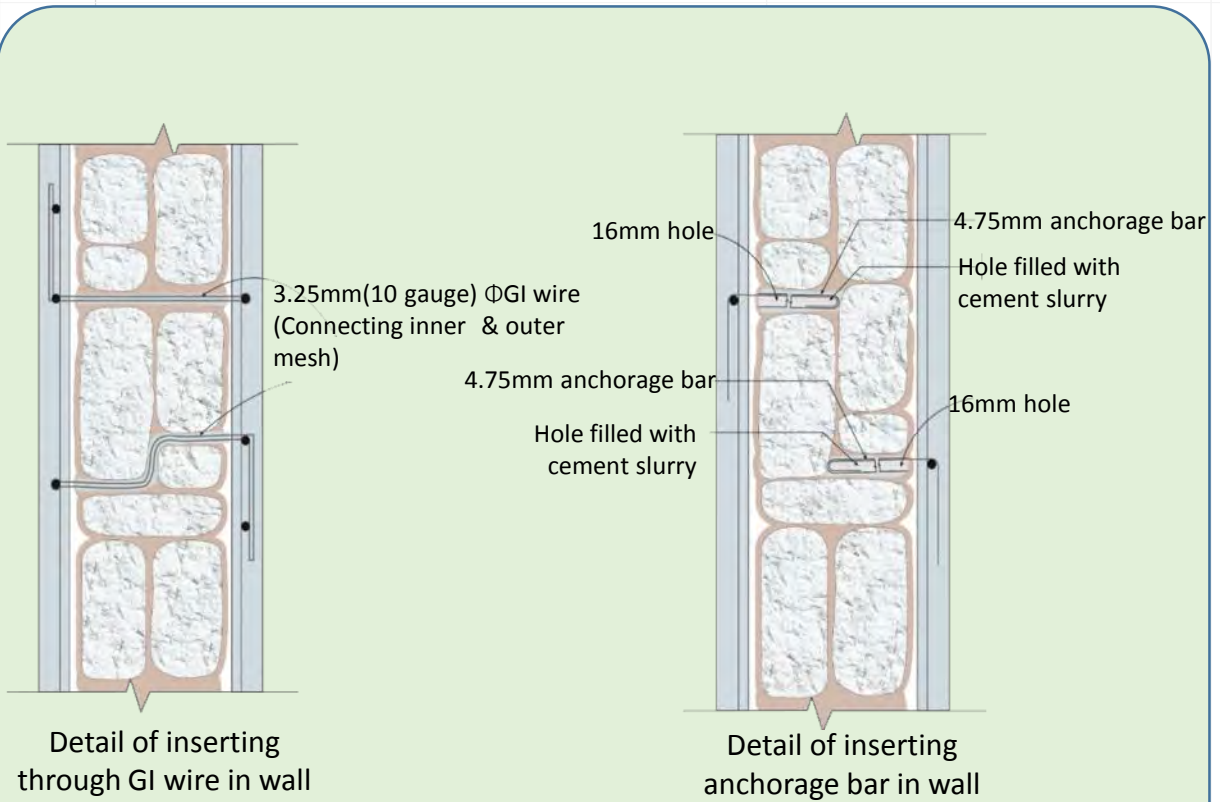



Detail of anchorage

Detail of fixing RC band

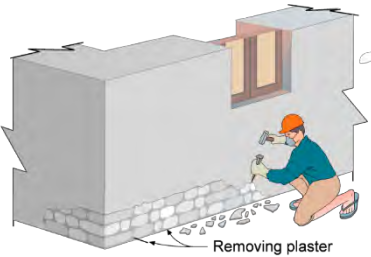
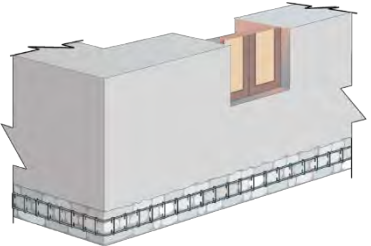

# 8. Adding RC Horizontal band

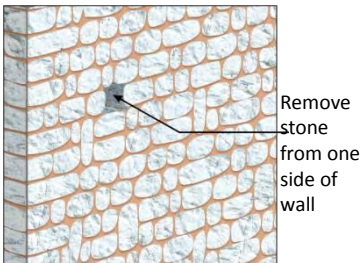
## Construction procedure

Step	Description of work	Images
1.	<p><b>Surface Preparation:</b></p> <ul style="list-style-type: none"> <li>Remove the plaster from the areas of the wall where bandages are to be placed.</li> <li>Rake out mortar up to the depth of ½"-1"</li> <li>Clean the surface, but don't use water for cleaning as mud mortar will be removed</li> <li>Apply a thin layer of cement slurry on these area</li> </ul>	 <p>Removing plaster</p>
2.	<p><b>Placing of Reinforcement</b></p> <ul style="list-style-type: none"> <li>Place horizontal steel bar mesh of bandages.</li> <li>Place stirrups on bandages</li> <li>(Note: Lapping of steel bars wherever required should be equal to development length: <ul style="list-style-type: none"> <li>4.75mm bar- 300mm lap</li> <li>8 mm bar- 450mm lap</li> <li>10 mm bar- 600mm lap</li> <li>12 mm bar- 720mm lap</li> <li>16 mm bar- 960mm lap)</li> </ul> </li> </ul>	
3.	<p><b>Make holes for anchorage</b></p> <p>i) For through GI wire :</p> <ul style="list-style-type: none"> <li>Make through holes in mud mortar on walls using steel rod and hammer at suggested locations</li> <li>Insert GI wires at suggested interval and location</li> <li>When it is not possible to make a straight hole through the wall: <ul style="list-style-type: none"> <li>Remove stone on one side of wall, then insert a GI wire through the wall by bending it.</li> <li>Place the removed stone back into the wall using mortar.</li> </ul> </li> </ul> <p>ii) For anchorage bar :</p> <ul style="list-style-type: none"> <li>Make holes on one wyth of wall using steel rod and hammer</li> <li>Insert steel anchorage bars at suggested interval and location</li> <li>When it is not possible to make a hole on wall: <ul style="list-style-type: none"> <li>Remove stone on one wyth of wall, then place anchorage bar</li> <li>Place the removed stone back into the wall using mortar</li> </ul> </li> </ul>	  <p>Remove stone from one side of wall</p>

## 8. Adding RC Horizontal band

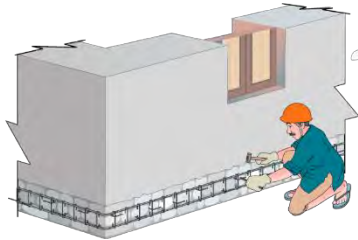
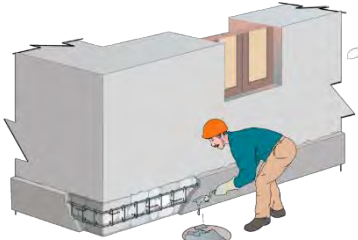
### Construction procedure

Step	Description of work	Images
4.	<b>Anchor reinforcing bar mesh</b> <ul style="list-style-type: none"><li>• Fix reinforcing bars into the wall using inserted steel anchorage bars, seal the anchorage bar using cement slurry</li><li>• Connect inner and outer mesh using inserted through G.I. wires</li></ul>	
5.	<b>Application of Micro Concrete</b> <ul style="list-style-type: none"><li>• Apply micro concreting on the reinforced splint and bandages with rich micro-concrete (M15) -20 to 25 mm thick in two layers. (Total thickness is 40-50mm)</li><li>• Micro concreting can be done by hand, similar to plastering, without shotcrete machine like in plastering.</li></ul>	
6.	<b>Curing of concrete</b> <ul style="list-style-type: none"><li>• Cure the concrete for 14days.</li><li>• Use jute bags/ mats for better curing</li></ul>	



## 9. Adding bandage (GI wire mesh)

Option 2: Provide welded GI wire mesh bandages on outer faces of wall wherever required and anchor them sufficiently with the wall as shown in the following figures

When it is not possible to transport concrete and steel to the site:

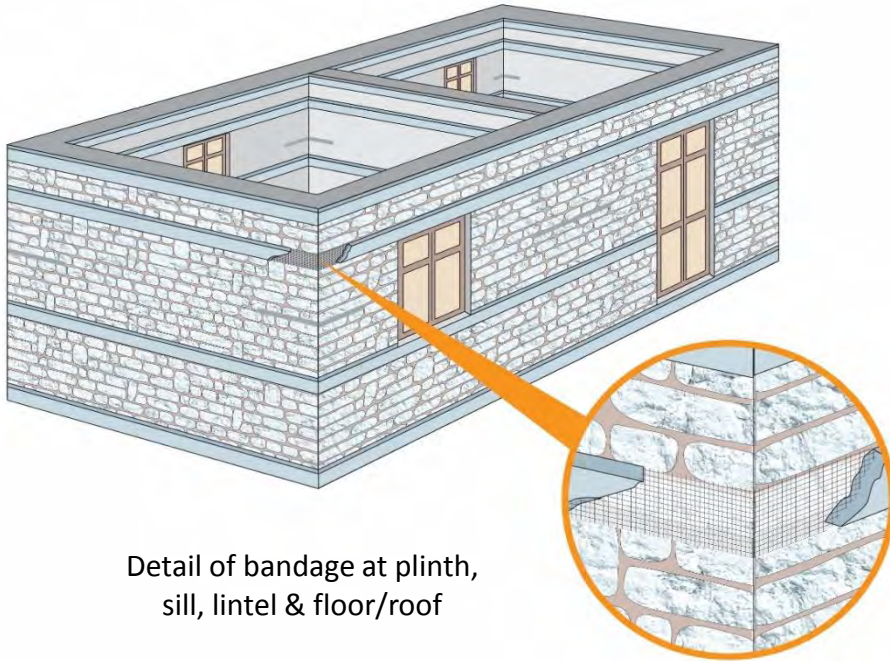

Detail of bandage at plinth, sill, lintel & floor/roof

Sill & Plinth band

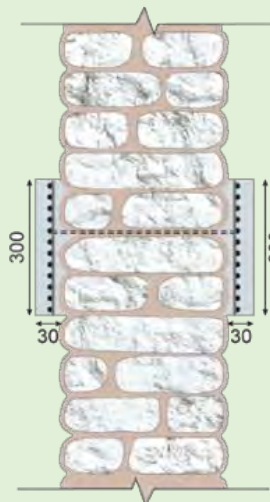

Lintel & Floor band

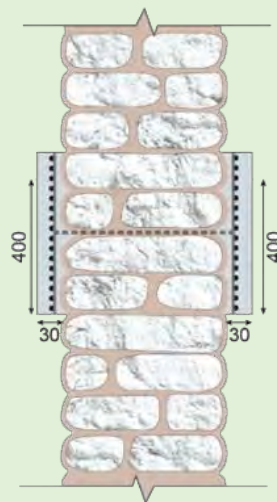

Welded GI wire mesh

10 gauge(3.24 mm)Φ bar @ 25 mmc/c

1:3 cement sand plaster or

Stabilized mud mortar plaster

Details of bandage

## 9. Adding bandage (GI wire mesh)

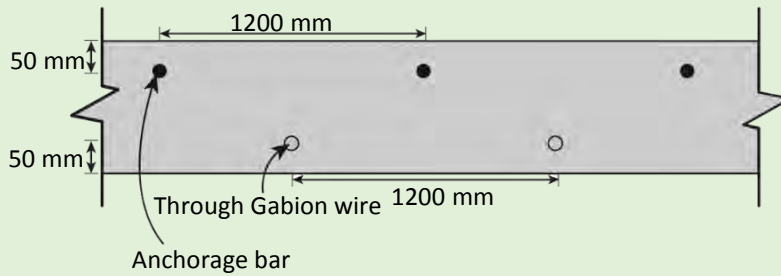
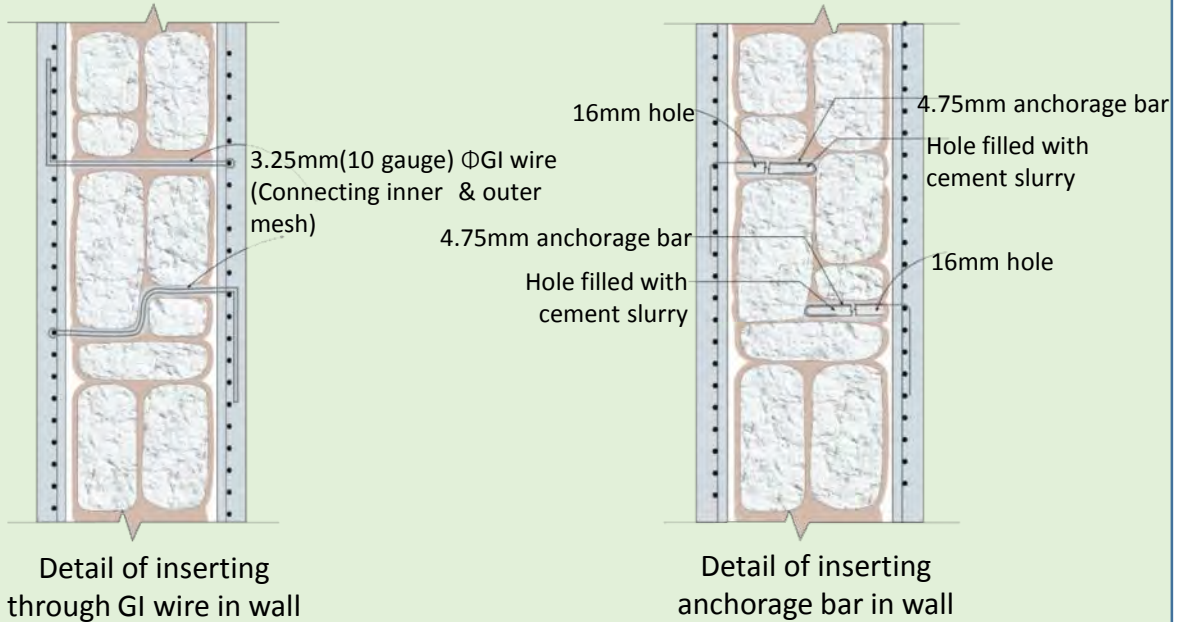





Detail of anchorage

Detail of fixing RC band

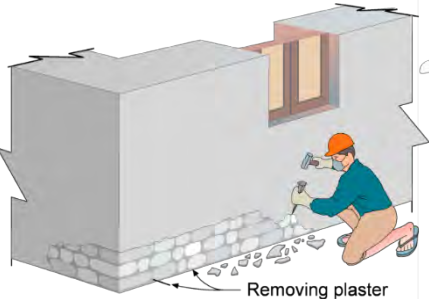

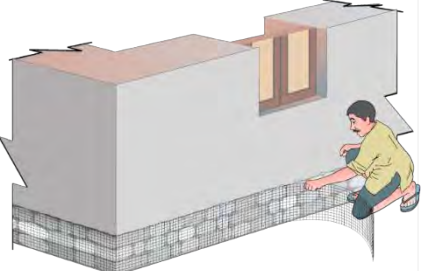
# 9. Adding bandage (GI wire mesh)

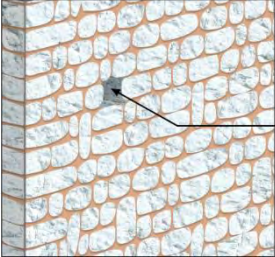
## Construction procedure

Step	Description of work	Images
1.	<p><b>Surface Preparation:</b></p> <ul style="list-style-type: none"> <li>Remove the plaster from the areas of the wall where bandages are to be placed.</li> <li>Rake out mortar upto the depth of ½"-1"</li> <li>Clean the surface, but don't use water for cleaning as mud mortar will flow</li> <li>Apply a thin layer of cement slurry on these areas</li> </ul>	 <p>Removing plaster</p>
2.	<p><b>Painting of GI wire mesh</b></p> <ul style="list-style-type: none"> <li>Welded GI wire mesh generally available in market are not galvanized properly, hence get corroded easily.</li> <li>Hence to prevent it from corrosion, paint it with Black Japan Paint or Bitumen emulsion paint</li> </ul>	 <p>Black Japan</p>
3.	<p><b>Placing of GI wire mesh</b></p> <ul style="list-style-type: none"> <li>Place horizontal GI wire mesh of bandages (Note: Lapping of mesh wherever required should be minimum 1 feet.)</li> </ul>	
4.	<p><b>Make holes for anchorage</b></p> <p>i) For through GI wire :</p> <ul style="list-style-type: none"> <li>Make through holes in mud mortar on walls using steel rod and hammer at suggested locations</li> <li>Insert GI wires at suggested interval and location</li> <li>When it is not possible to make a straight hole through the wall: <ul style="list-style-type: none"> <li>Remove stone on one side of wall, then insert a GI wire through the wall by bending it.</li> <li>Place the removed stone back into the wall using mortar.</li> </ul> </li> </ul> <p>ii) For anchorage bar :</p> <ul style="list-style-type: none"> <li>Make holes in one wyth of wall using steel rod and hammer</li> <li>Insert steel anchorage bars at suggested interval and location</li> <li>When it is not possible to make a hole in the wall: <ul style="list-style-type: none"> <li>Remove stone on one wyth of wall, then place anchorage bar</li> <li>Place the removed stone back into the wall using mortar</li> </ul> </li> </ul>	  <p>Remove stone from one side of wall</p>

## 9. Adding bandage (GI wire mesh)

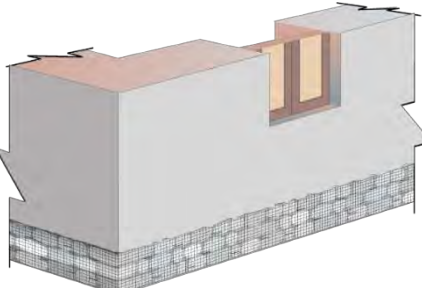
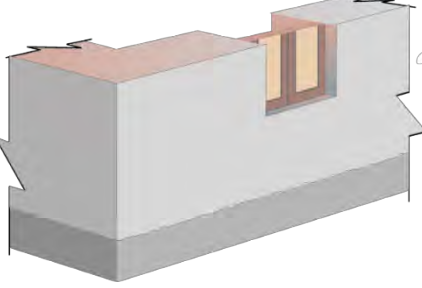

### Construction procedure

Step	Description of work	Image
5.	<p><b>Anchor GI wire mesh</b></p> <ul style="list-style-type: none"> <li>• Connect inner and outer mesh using inserted through G.I. wires</li> <li>• Fix mesh into the wall using inserted steel anchorage bars, seal the anchorage bar using cement slurry</li> </ul>	
6.	<p><b>Plastering</b></p> <ul style="list-style-type: none"> <li>• Apply 1:3 plaster about 1/2" thick in two layers. (Total thickness is 1") Or</li> <li>• Apply stabilized mud mortar plaster if cement is not available</li> </ul>	
7.	<p><b>Curing of plaster</b></p> <ul style="list-style-type: none"> <li>• In case of cement sand plaster, cure the plaster area for 7 days.</li> <li>• Use jute bags/ mats for better curing</li> </ul>	

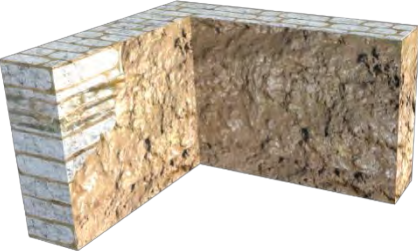
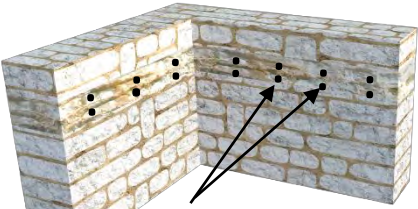

# 10. Adding Horizontal band (Wood)

## Construction procedure

Step	Description of work	Images
1.	<p><b>Surface preparation:</b></p> <ul style="list-style-type: none"> <li>Remove the plaster from the areas of the wall where reinforcements are to be placed.</li> <li>Rake out the mortar up to a depth of ½”-1”.</li> <li>Clean the surface, but do not use water for cleaning as the mud mortar will be removed.</li> <li>Apply a thin layer of cement slurry on these areas.</li> </ul>	
2.	<p><b>Make holes for anchorage:</b></p> <ul style="list-style-type: none"> <li>Make through holes in mud mortar on walls using steel rod and hammer at 300mm c/c.</li> <li>Insert GI wires at suggested intervals and location.</li> <li>When it is not possible to make a straight hole through the wall:               <ul style="list-style-type: none"> <li>Remove stones on one side of the wall, then insert a GI wire through the wall by bending it.</li> <li>Place the removed stone back into the wall using mortar.</li> </ul> </li> </ul>	 <p>Drilled holes @300mmc/c</p>
3.	<p><b>Installation of horizontal wooden member:</b></p> <ul style="list-style-type: none"> <li>Place 75mmX38mm horizontal wooden member on either side of wall.</li> </ul>	
4.	<p><b>Anchor GI wire mesh:</b></p> <ul style="list-style-type: none"> <li>Connect the horizontal wooden member with the wall using inserted GI mesh, seal the mesh using cement slurry or mud plaster.</li> </ul>	

## 10. Adding Horizontal band (Wood)

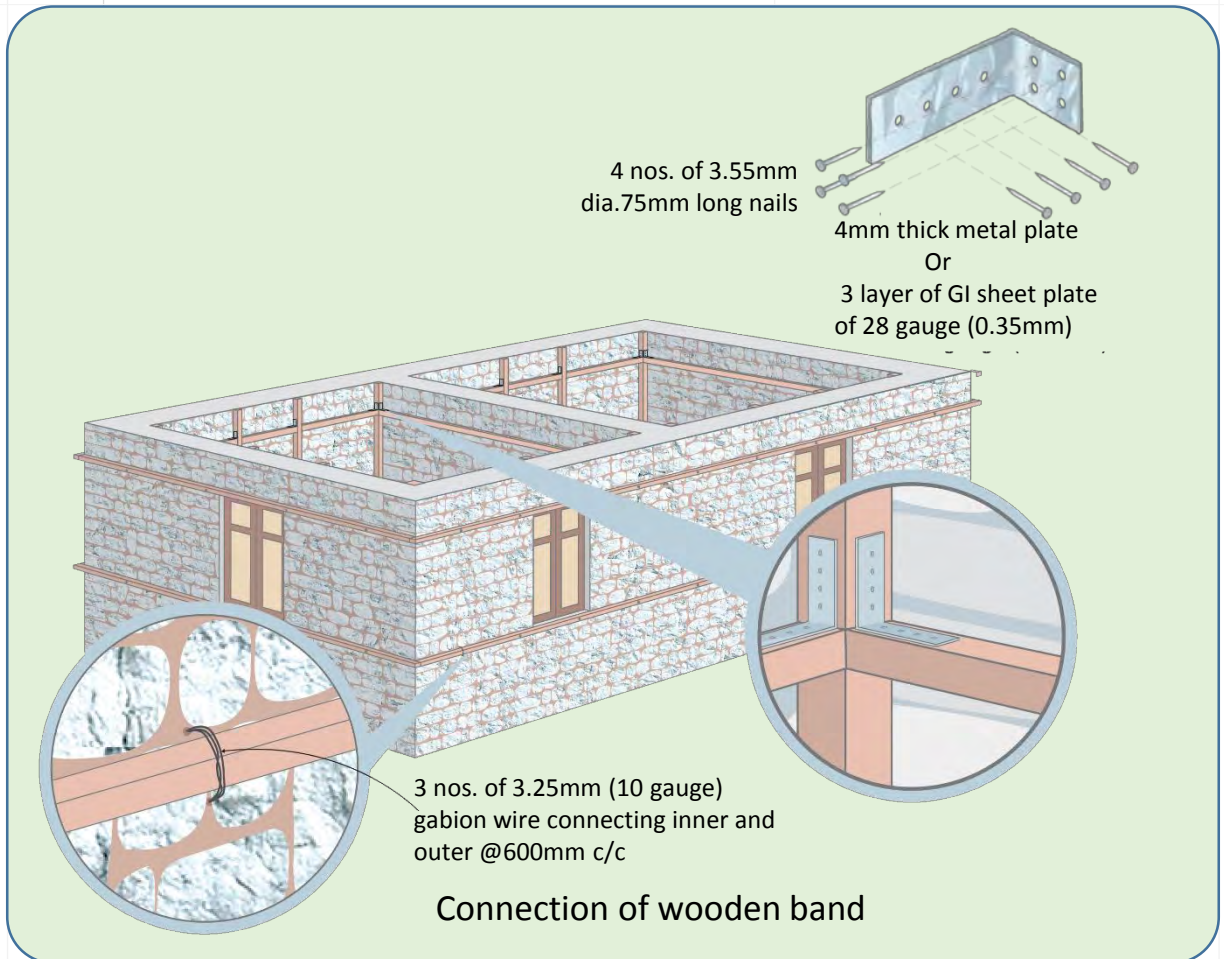

# 11. Strengthen wall by Jacketing

## Option1: GI welded wire mesh jacketing

When both horizontal and vertical reinforcements are missing:



GI welded wire mesh



For full jacketing covered by cement mortar, 16 gauge galvanized wire mesh with 19mm c/c spacing can be used with anchoring on both sides of the wall.



Construction procedure



# 11. Strengthen wall by Jacketing

## Option2: Gabion wire mesh jacketing

When both horizontal and vertical reinforcements are missing.

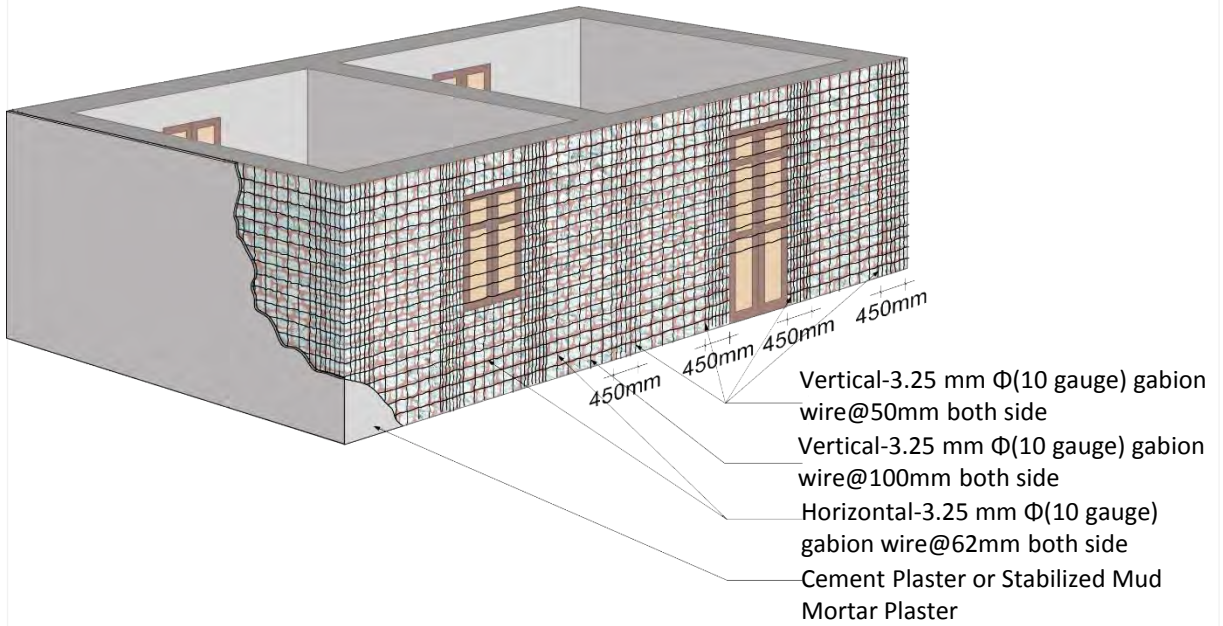

Details of gabion wire mesh jacketing



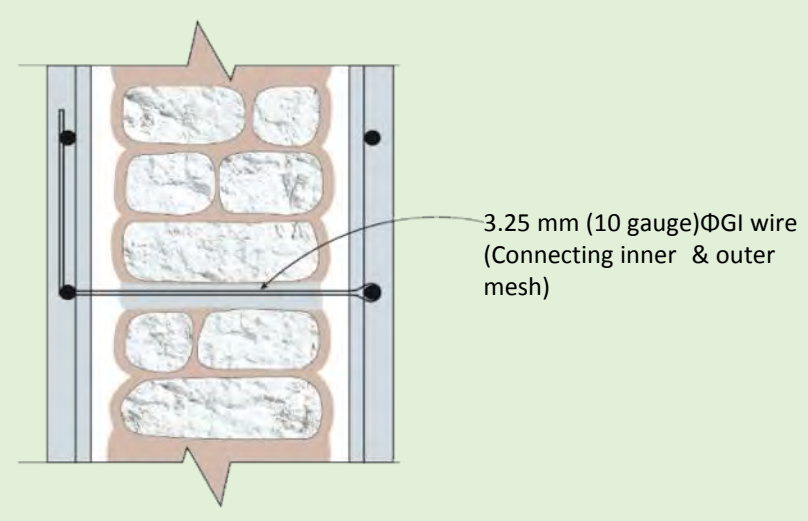
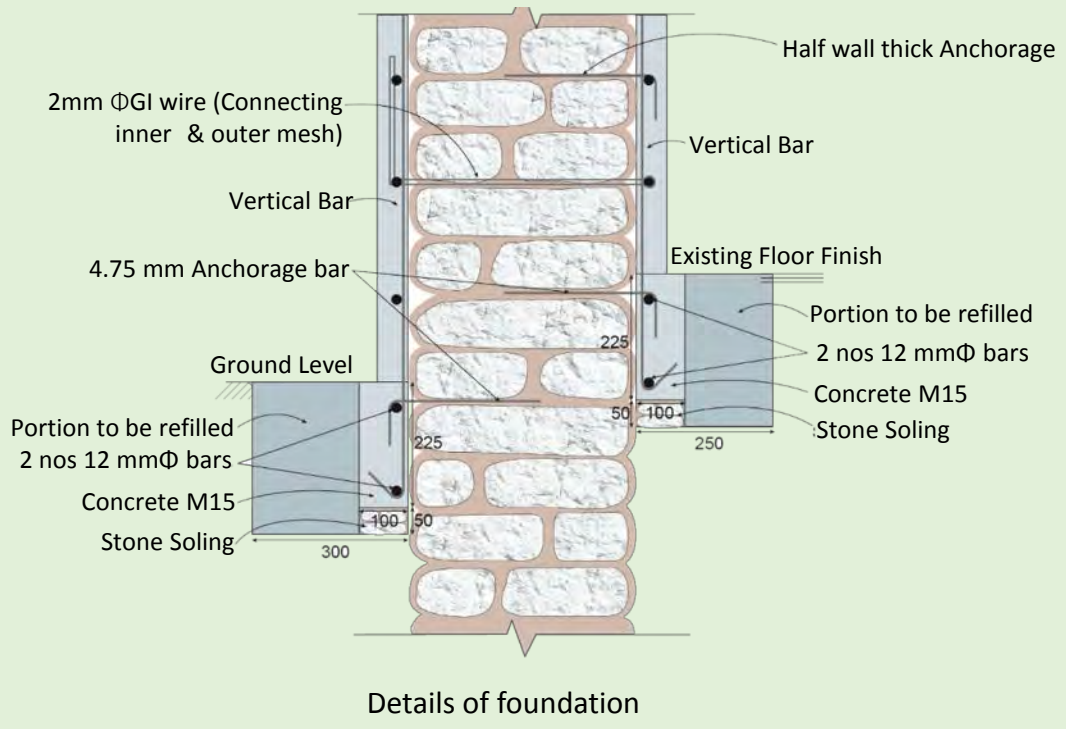

# 11. Strengthen wall by Jacketing



Details of anchorage of gabion wire mesh with wall

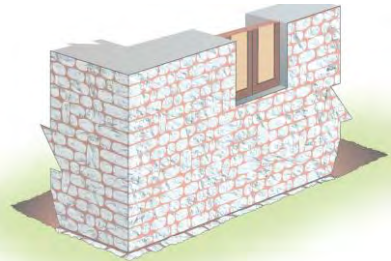

# 11. Strengthen wall by Jacketing

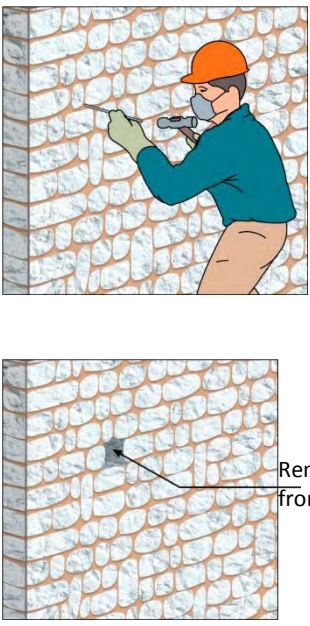
## Construction procedure

Step	Description of work	Images
1.	<b>Surface Preparation:</b> <ul style="list-style-type: none"> <li>Remove the plaster from the wall</li> </ul>	
2.	<b>Foundation preparation:</b> <ul style="list-style-type: none"> <li>Dig out trench around foundation for placing tie beams for vertical gabion wire anchorage.</li> <li>Stone soling in the trench</li> </ul>	
3.	<b>Painting Gabion wire</b> <ul style="list-style-type: none"> <li>Gabion wire generally available in markets is not galvanized properly, and corrodes easily.</li> <li>To prevent gabion wires from corrosion, paint with Black Japan Paint or Bitumen emulsion paint</li> </ul>	
4.	<b>Make holes for anchorage</b> <ul style="list-style-type: none"> <li>Make through holes in mud mortar on walls using steel rod and hammer at suggested locations</li> <li>Insert GI wires at suggested interval and location</li> <li>When it is not possible to make a straight hole through the wall: <ul style="list-style-type: none"> <li>Remove stone on one side of wall, then insert a GI wire through the wall by bending it</li> <li>Place the removed stone back into the wall using mortar</li> </ul> </li> </ul>	

# 11. Strengthen wall by Jacketing

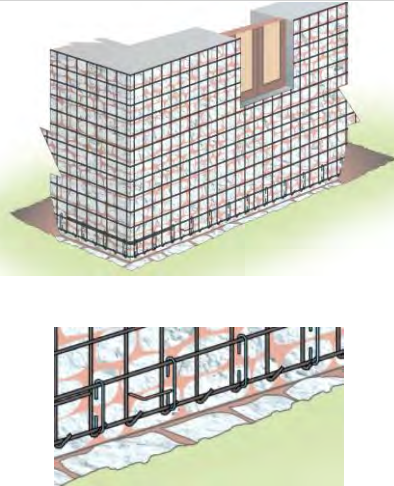
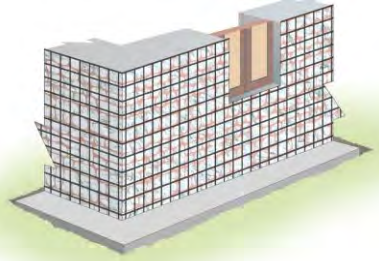
## Construction procedure

Step	Description of work	Images
5.	<p><b>Placing of Gabion wire mesh</b></p> <ul style="list-style-type: none"> <li>Place the horizontal bars in the trench</li> <li>Now, place vertical Gabion wire mesh at suggested interval</li> <li>Anchor them to the steel bar in the trench</li> <li>Connect the vertical wires properly to the wall at the top also</li> <li>Then, tie the horizontal Gabion wire mesh with the vertical gabion wires at suggested intervals</li> </ul> <p>(Note: Lapping of wire wherever required should be minimum 1 feet.)</p>	
6.	<p><b>Concreting of foundation beam</b></p>	
7.	<p><b>Anchor GI wire mesh</b></p> <ul style="list-style-type: none"> <li>Connect inner and outer mesh using inserted through G.I. wires</li> </ul>	
8.	<p><b>Plastering</b></p> <ul style="list-style-type: none"> <li>If possible plaster the mesh using stabilized mud mortar or it can be kept exposed as well.</li> </ul>	

# 11. Strengthen wall by Jacketing

## Option3: PP (Polypropylene) band mesh jacketing

When both horizontal and vertical reinforcements are missing:

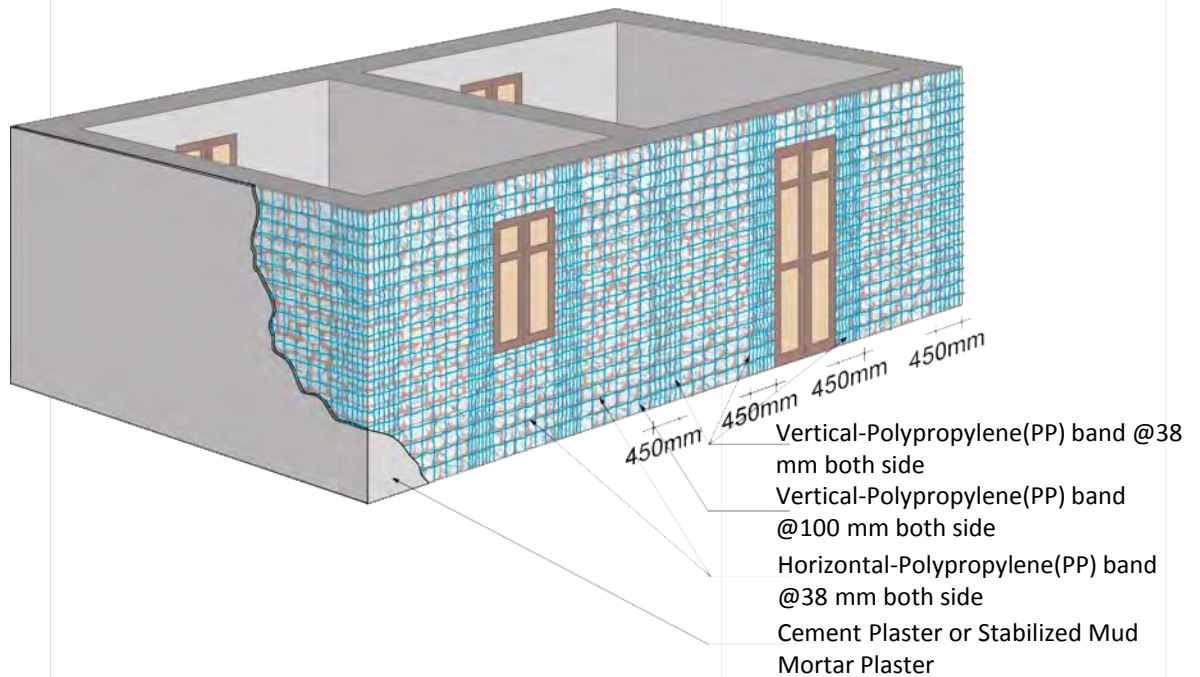

Details of PP (Polypropylene) band mesh jacketing



# 11. Strengthen wall by Jacketing

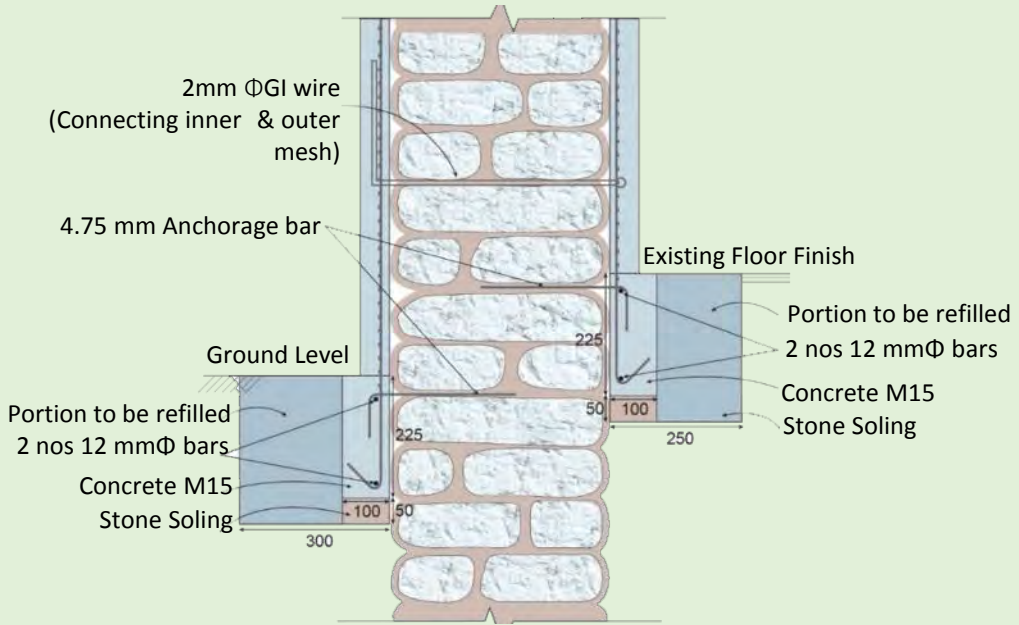

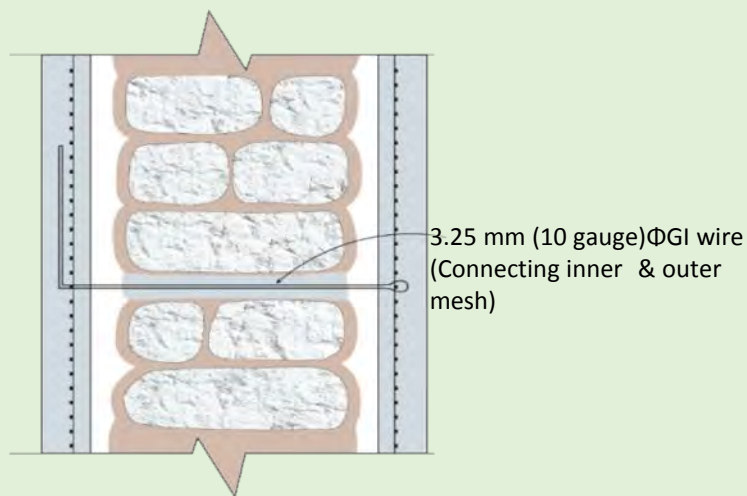

Details of foundation



Details of anchorage of PP band mesh with wall

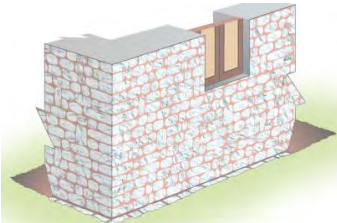

# 11. Strengthen wall by Jacketing

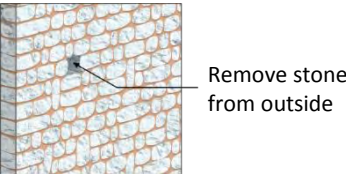
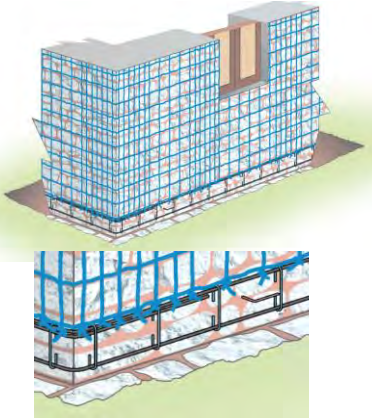
## Construction procedure

Step	Description of work	Images
1.	<p><b>Surface preparation:</b></p> <ul style="list-style-type: none"> <li>Remove the plaster from the wall</li> </ul>	
2.	<p><b>Foundation preparation:</b></p> <ul style="list-style-type: none"> <li>Dig out trench around foundation for placing tie beams for vertical PP band anchorage</li> <li>Stone soling on the trench</li> </ul>	
3.	<p><b>Make holes for anchorage:</b></p> <ul style="list-style-type: none"> <li>Make through holes in mud mortar on walls using steel rod and hammer at suggested locations</li> <li>Insert GI wires at suggested interval and location</li> <li>When it is not possible to make a straight hole through the wall: <ul style="list-style-type: none"> <li>Remove stone on one side of wall, then insert a GI wire through the wall by bending it</li> <li>Place the removed stone back into the wall using mortar</li> </ul> </li> </ul>	 
4.	<p><b>Installation of PP band.</b></p> <ul style="list-style-type: none"> <li>Place the horizontal bars in the trench</li> <li>Now, place vertical PP band mesh at suggested interval</li> <li>Tie them to the steel bar in the trench</li> <li>Then, place horizontal PP band mesh at suggested intervals</li> <li>Connect the vertical and horizontal bands by welding (Note: Lapping of PP band wherever should be minimum 1 feet.)</li> </ul>	

# 11. Strengthen wall by Jacketing

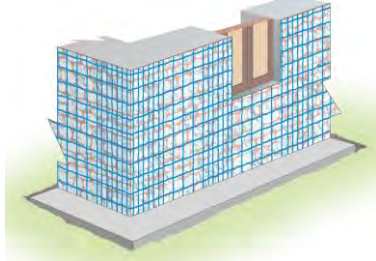
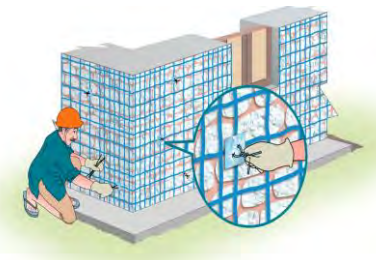
## Construction procedure

Step	Description of work	Images
5.	Concreting of foundation beams.	
6	<b>Anchor GI wire mesh</b> <ul style="list-style-type: none"><li>• Connect inner and outer mesh using inserted through G.I. wires and aluminum plate</li></ul>	
7.	<b>Plastering</b> Plaster the mesh using stabilized mud mortar	

This Page is Intentionally Left Blank



This Page is Intentionally Left Blank

## ANNEX I

# Option 1. Wooden frame with wooden connection

## OPTION 1

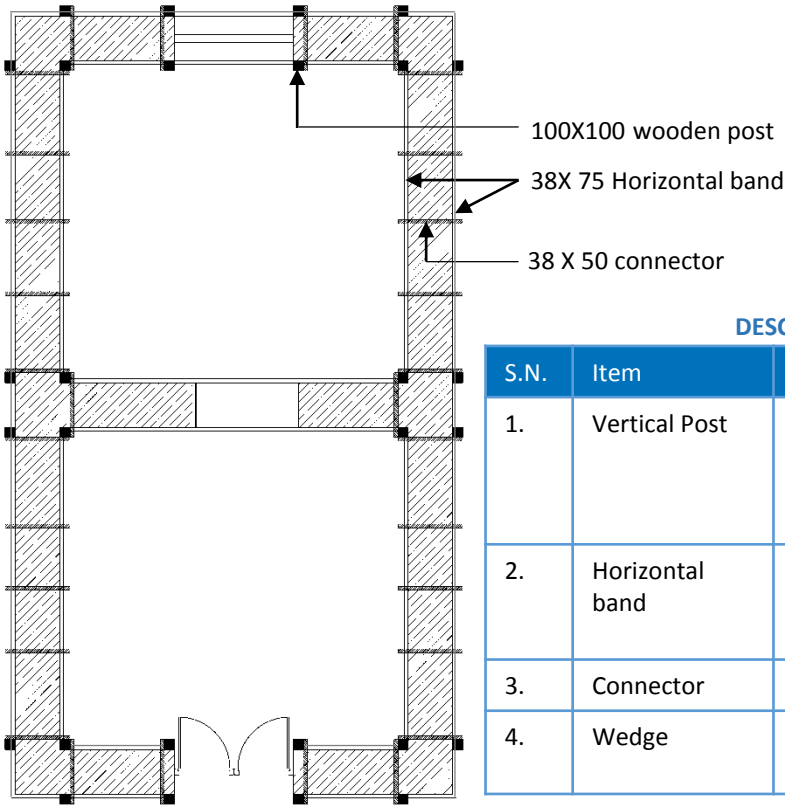

### DESCRIPTION

S.N.	Item	Size & Spacing (mm)	Remarks
1.	Vertical Post	100 X 100 rectangular or 100 dia circular @ corner & side of opening	
2.	Horizontal band	38X75 at plinth, sill, lintel & roof level @ both side of wall	
3.	Connector	38X50 @750 to 900	
4.	Wedge	15X15 wedge/12mm metal rod	

### FLOOR PLAN (STONE MASONRY)

#### Typical Wooden plinth, sill, lintel & Roof band

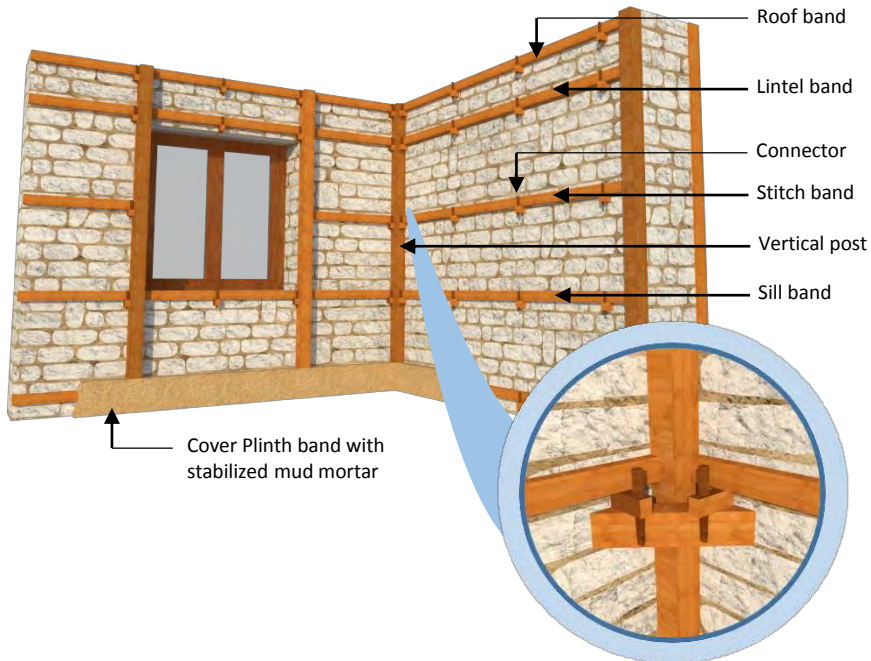

#### Note:

- *Stitch band can be constructed depending upon the structure*
- *Diagonal bracing may required in some cases.*

# Option2. Wooden frame and corner with diagonal bracing with wooden connection

## OPTION 2

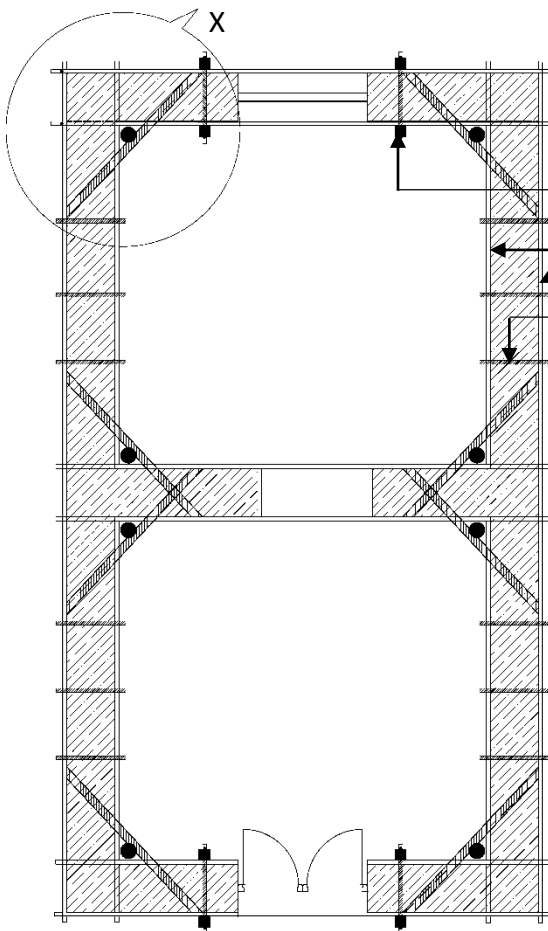

Wooden post  
(100X100 rectangular post/100 dia circular post)  
38X 75 Horizontal band  
38X 50 connector @ 750 to 900 c/c

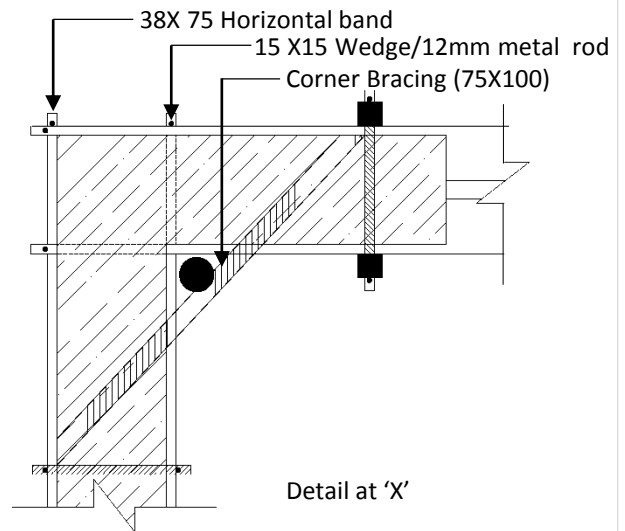

Detail at 'X'

### FLOOR PLAN (STONE MASONRY)

Typical Wooden plinth, sill, lintel & Roof band

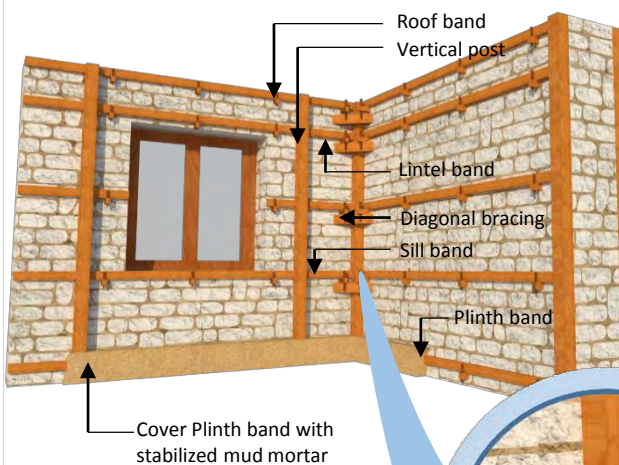

### DESCRIPTION

S.N	Item	Size & Spacing (mm)	Remarks
1.	Vertical Post	100 X 100 rectangular or 100 dia circular @ corner & side of opening	
2.	Horizontal band	38X75 at plinth, sill, lintel & roof level@ both side of wall	
3.	Corner bracing	75X100 @each corner	
4.	Connector	38X50 @750 to 900	
5.	Wedge	15X15 wedge/12mm metal rod	



# Option 3. Wooden frame with iron nut bolt connection

## OPTION 3

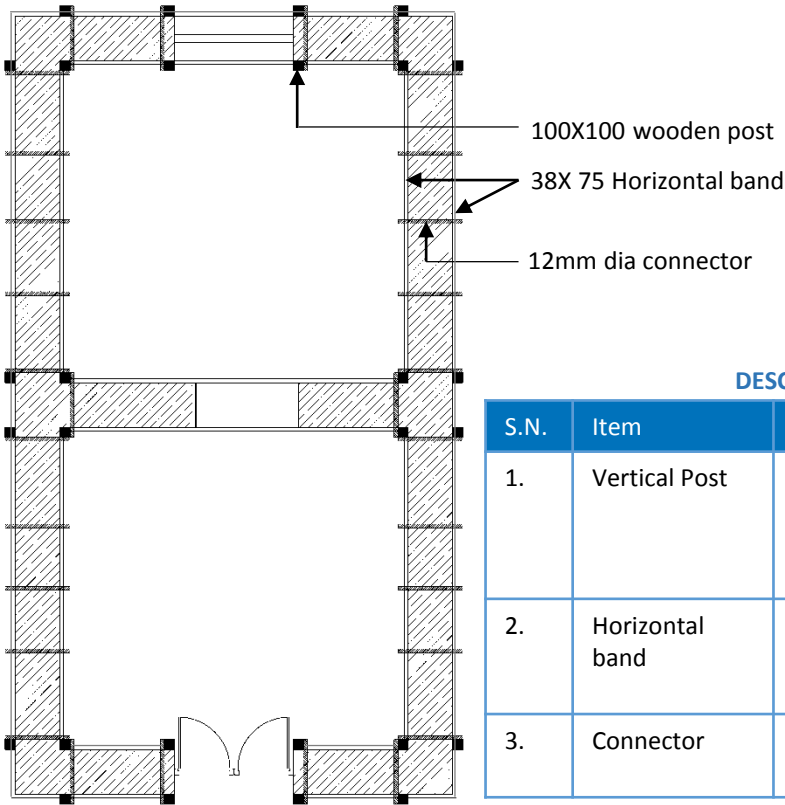

### DESCRIPTION

S.N.	Item	Size & Spacing (mm)	Remarks
1.	Vertical Post	100 X 100 rectangular or 100 dia circular @ corner & side of opening	
2.	Horizontal band	38X75 at plinth, sill, lintel & roof level @ both side of wall	
3.	Connector	12mm dia @ 750 to 900mm c/c	Iron nut bolt

### FLOOR PLAN (STONE MASONRY)

Typical Wooden plinth, sill, lintel & Roof band

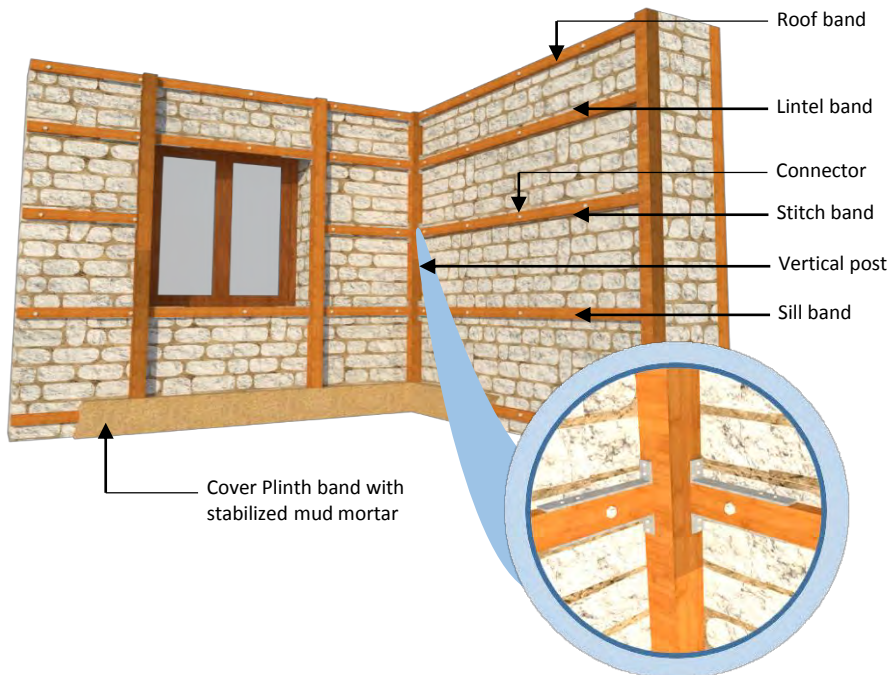

# Option 4. Wooden frame and corner diagonals with iron rod connection

## OPTION 4

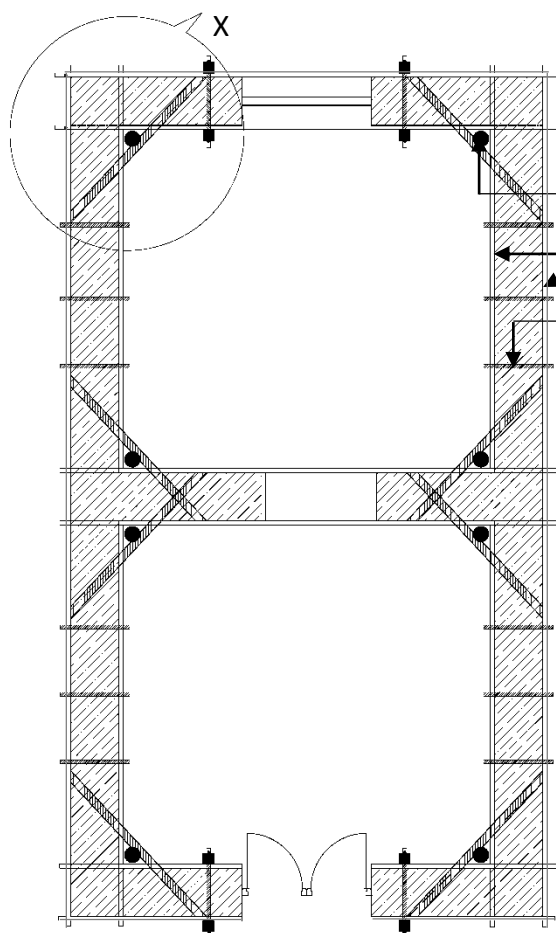

Wooden post  
(100X100 rectangular post/100 dia circular post/  
16mm dia rod)  
38X 75 Horizontal band  
12mm dia connector @ 750 to 900 c/c

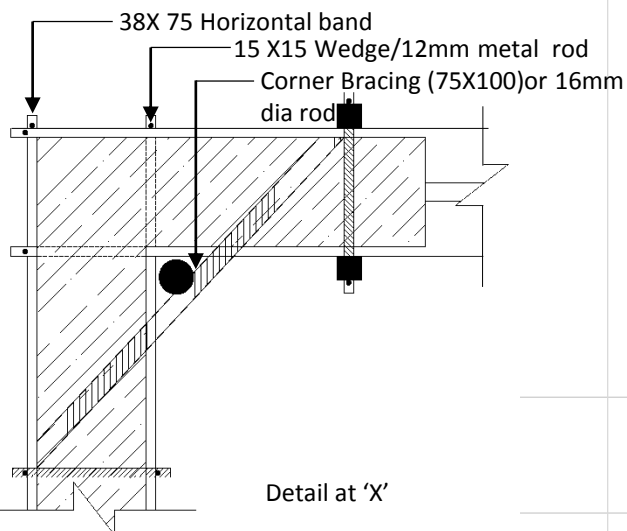

### FLOOR PLAN (STONE MASONRY)

Typical Wooden plinth, sill, lintel & Roof band

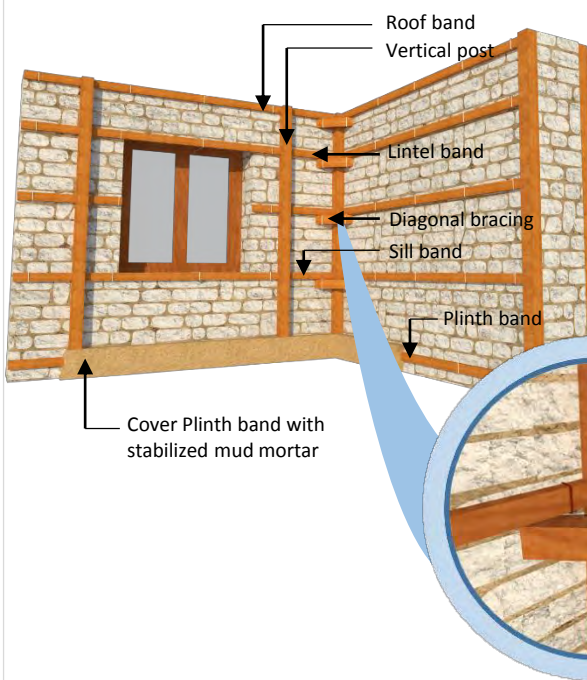

### DESCRIPTION

S.N	Item	Size & Spacing (mm)	Remarks
1.	Vertical Post	100 X 100 rectangular or 100 dia circular or 16mm rod @ corner & side of opening	
2.	Horizontal band	38X75 at plinth, sill, lintel & roof level@ both side of wall	
3.	Corner bracing	75X100 each corner or 16mm rod	
4.	Connector	12mm dia rod@750 to 900	

# Option 5. Gabion Wire Wrappings

## OPTION 5

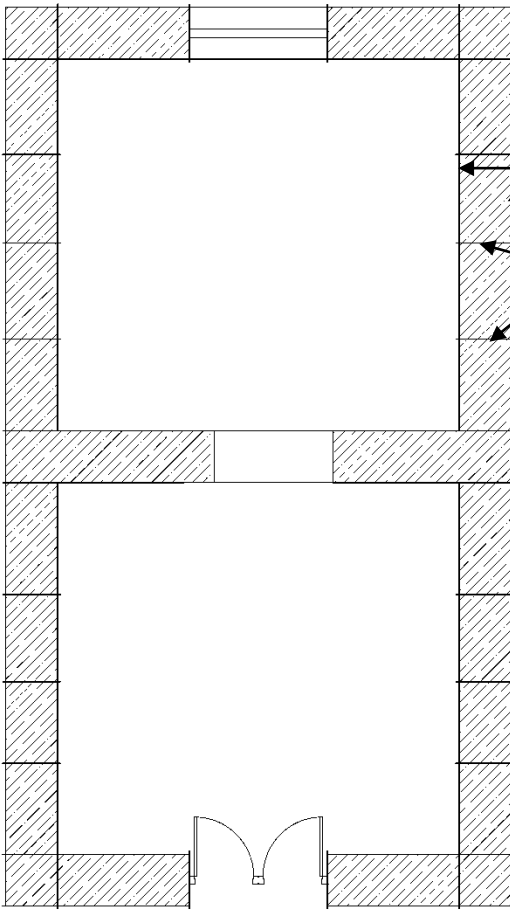

DESCRIPTION			
S.N.	Item	Size & Spacing (mm)	Remarks
1.	Gabio wire	10 Guage (3.24mm dia) 300mm width gabion wire @ plinth/sill/stitch/lin tel/Roof band.	
2.	Connector	10 guage (3.24mm dia)@750 to 900mm c/c	

### FLOOR PLAN (STONE MASONRY)

Typical Wooden plinth, sill, lintel & Roof band

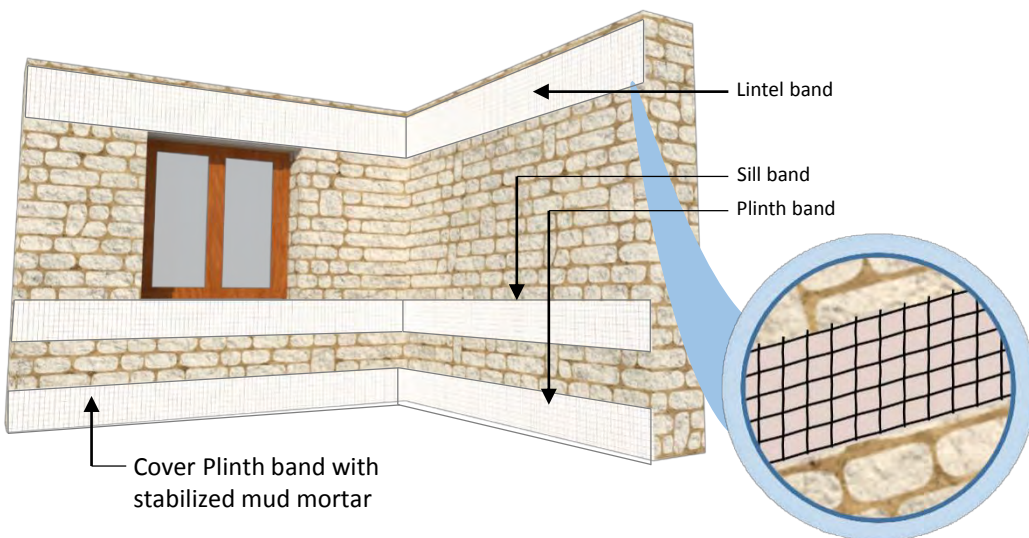

\* Note: Please refer mitigation measures:9 Adding bandage(GI wire mesh) page 56

# 6. Precast concrete frame with Iron rod connection

## OPTION 6

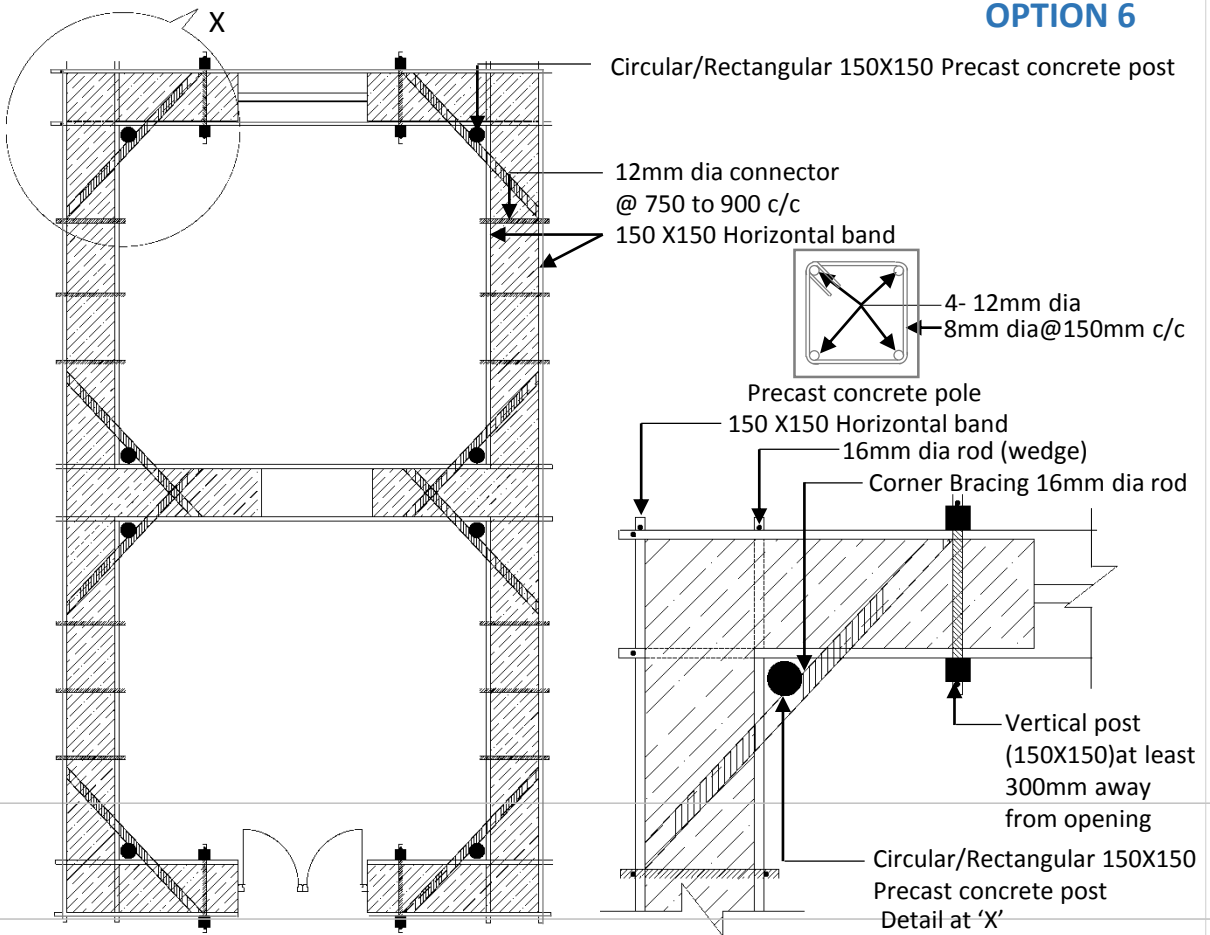

### FLOOR PLAN (STONE MASONRY)

Typical Wooden plinth, sill, lintel & Roof band

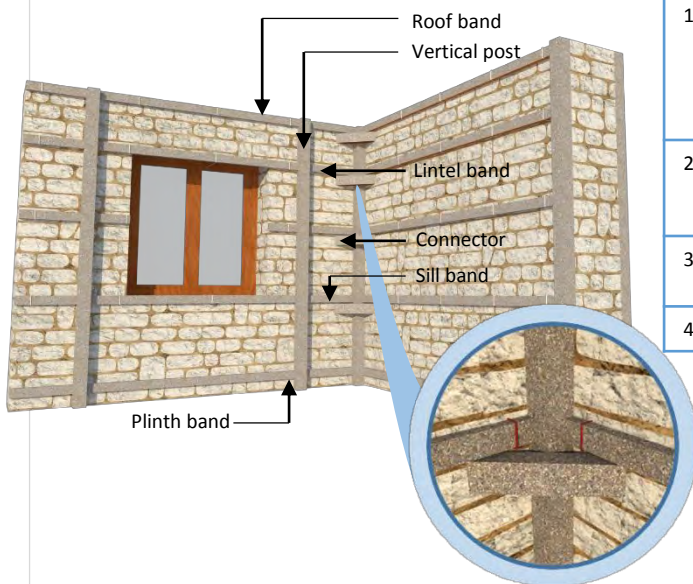

### DESCRIPTION

S.N.	Item	Size & Spacing (mm)	Remarks
1.	Vertical Post	150 X 150 rectangular or 150 dia circular @ corner & side of opening <i>*Note: Precast concrete should be 4-12mm dia</i>	Precast concrete
2.	Horizontal band	150 X 150 at plinth, sill, lintel & roof level @ both side of wall	Precast concrete
3.	Connector	12mm dia rod @ 750 to 900	Iron rod
4.	Wedge	12mm dia bar	Iron rod



This Page is Intentionally Left Blank

## ANNEX II

# Option 1. Use of Wooden/Bamboo Sections

## Building description:

<b>Plan area</b>	Approx. 55.8 square meter.
<b>Building height</b>	Approx. 2.75 meter.
<b>Occupancy</b>	It is a residential building for approximately five to seven membered family.
<b>Construction/ Material</b>	Ground floor made of stone in mud and first floor timber frame with CGI sheet partition. Roof is composed of timber with CGI sheet.
<b>Earthquake Resistant Element</b>	Wooden bands as per code are used

### Exception

- E1. If structure is found to safe after structural calculation
- E2. Overall Exception : If the construction is up to plinth level is as per requirement second tranche recommendation for second tranches can be recommended, correction or mitigation at super structure shall be made before third tranche.

### Solution

- Provide Vertical Wooden Post near openings, T, Corner Junction. Add diagonal Bracing as shown below.
- Make proper connection between lower and upper floor/Storey.
- Use environment friendly locally available materials such as bamboo mesh or other suitable materials.

### Correction

- Wooden Member Size: X-sectional area 100mmx100mm (equivalent bamboo)
- Member Connection: As per MRT or equivalent with Metal Nails or Timber Nails



Mix structures are considered safe, if lower masonry structure is as per requirement. For upper structure, bracing or vertical props with proper connections shall be advisable if not provided.

## Building description:

<b>Plan area</b>	Approx. 37.16 square meter
<b>Building height</b>	Approx. 2.75 meter, masonry 0.9 meter , remaining light partitions
<b>Occupancy</b>	It is a residential building for approximately five to seven membered family.
<b>Construction/ Material</b>	Single floor made of stone in mud/cement up to sill level and remaining height wooden frame with CGI sheet partition. Roof is composed of timber with CGI sheet.
<b>Earthquake Resistant Element</b>	Wooden bands as per code are used

### Exception

E1. If structure is found to safe after structural calculation

### Solution

- Provide Vertical Wooden Posts @ 1 m to 1.5 m spacing including near openings, T, Corner Junction. Add diagonal Bracing as shown below.

### Correction



Elevation (ground floor)

Wooden member size: X-sectional area 38mmx50mm (equivalent bamboo)  
 Member Connection: As per MRT or equivalent with Metal Nails or Wooden Nails



## Option 3. Use of Wooden/Bamboo Sections (Both side)

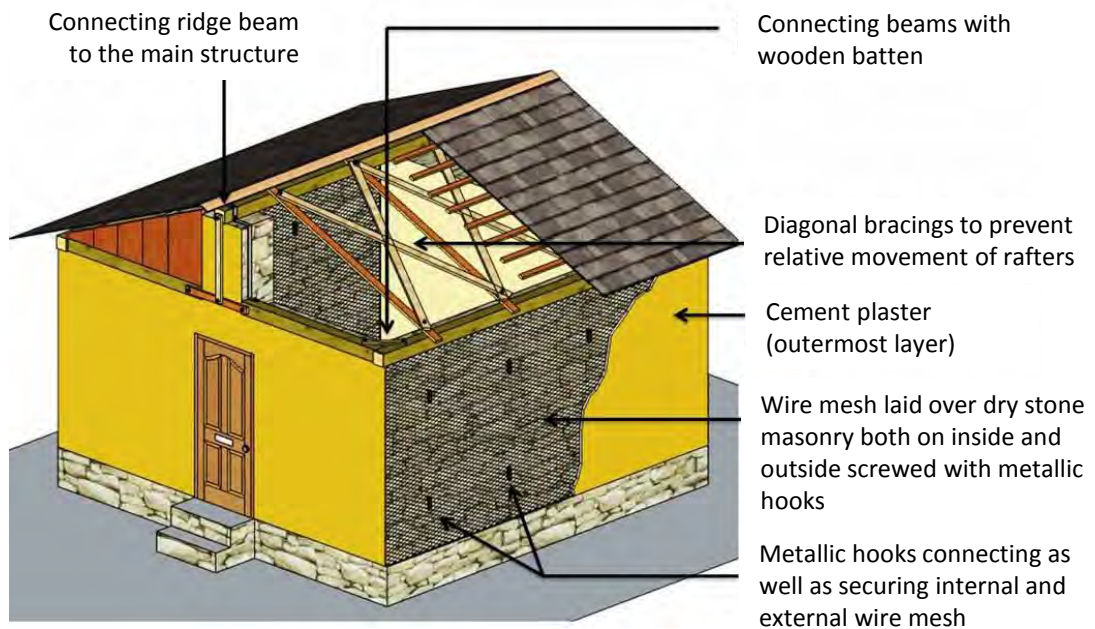
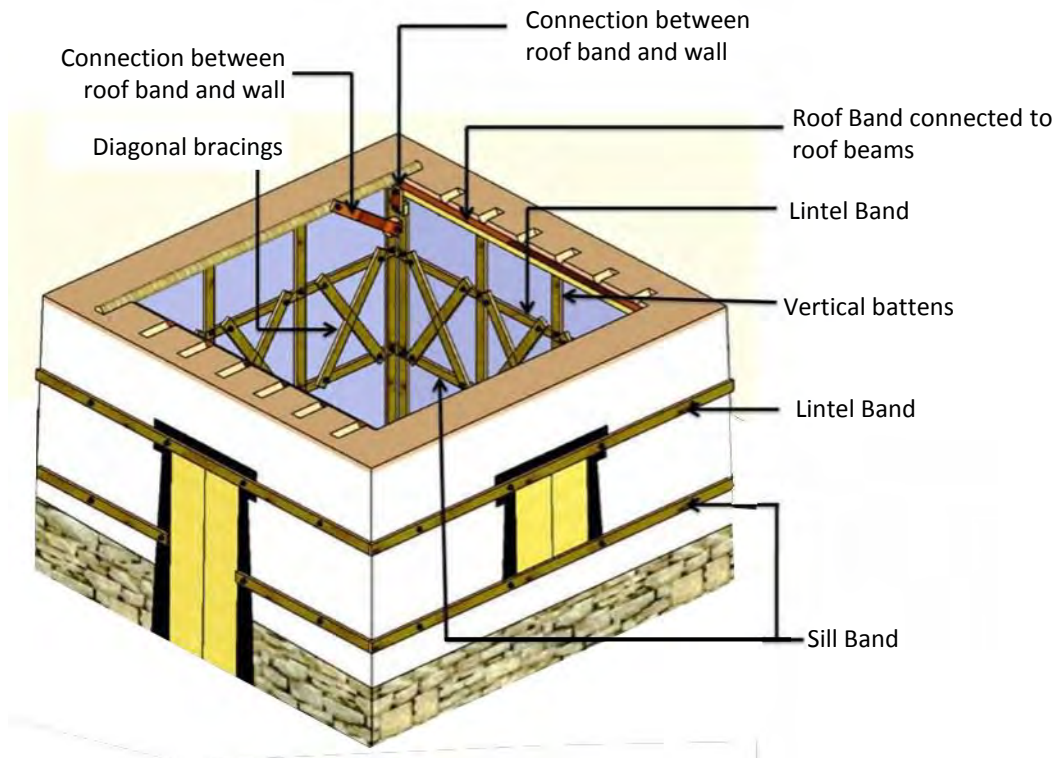

# Option 4. Use of Wooden/Bamboo Sections(Both side)

## Solution



Ground Floor Only



Ground Floor Only

### Connection details:



Vertical, Horizontal & Diagonal members connection using GI Wire (10 Gauge)



Vertical, Horizontal & Diagonal members connection using Lacing (Jute, Lylon, or equivalent) Techniques

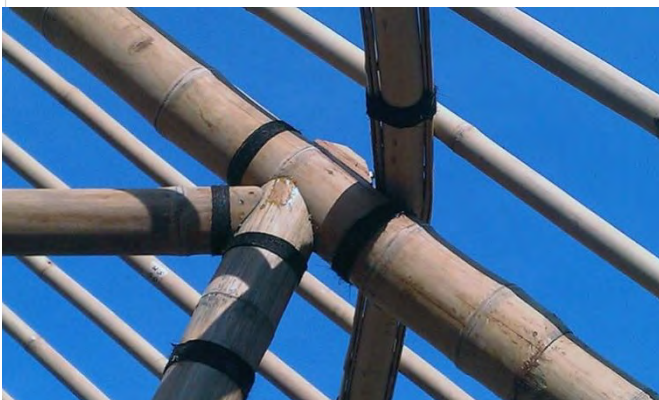

Vertical-Horizontal & Diagonal members fitting connection using lashing technique



One Vertical, Two Horizontal members fitting connection combined with lashing technique

## Option 5. Use of Iron Sections



*Note: Pictures shows only first floor for clarity*

### Building description:

- Mixed structural system
  - Ground floor: Masonry structure
  - First floor: Wooden light weight structure

### Exception

E1. If structure is found to safe after structural calculation

### Solution

- Provide Vertical Wooden Post near openings, T, Corner Junction. Add diagonal Bracing as shown below.
- Wooden member size: Equivalent to ISBN 40 (M) square hollow pipe
- Member connection: Fillet welding 3mm thick all around.



## Option 6. Use of Iron Sections with prefab panels



*Note: Pictures shows only first floor for clarity*

### Building description:

- Mixed structural system
  - Ground floor: Masonry structure
  - First floor: prefab panels with iron sections

### Exception

E1. As per Design and details by service provider and should be safe.

### Solution

- Wooden member size: As per Design and details by service provider
- Member connection: Fillet welding 3mm thick all around or Nut bolts.



This Page is Intentionally Left Blank





नेपाल सरकार  
राष्ट्रिय पुनर्निर्माण प्राधिकरण  
आवास पुनर्निर्माण कार्यक्रम  
सिंहदरवार, काठमाडौं  
फोन नं.: ०१४२००२६६, ४२१११०३  
इमेल: info@nra.gov.np